

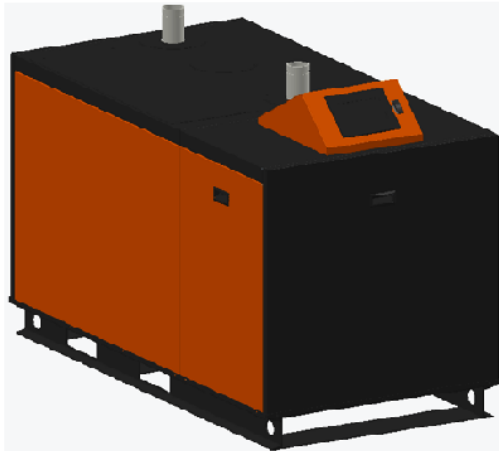

INSTALLATION, OPERATION AND MAINTENANCE MANUAL

Condensing Hydronic Boiler
Models: AMP 1000, 1250, 1500 & 2000



Boiler Mode: _____
Serial Number: _____
Installation Date: _____
Heating Contractor: _____

WARNING: Improper installation, adjustment, alteration, service or maintenance can cause property damage injury, or loss of life. For assistance or additional information, consult a qualified installer, service agency or the gas supplier. This boiler requires a special venting system. Read these instructions carefully before installing.

TABLE OF CONTENTS

I	Hazard Definitions	4
II	Read Before Proceeding	5-6
	A. Local Codes	
	B. Warranty	
	C. Shipment Damage	
	D. Boiler Operation	
	E. Gas Leakage (If you detect or smell gas...)	
	F. Maintenance	
	G. Freeze Protection Fluids	
	H. Product Identification Label	
	I. Factory Test and Inspections	
	J. Disclaimers and Local Codes	
III	Product Rating, Specifications and Dimensional Data	7-8
IV	Component Identification	10-13
V	Unpacking Boiler	14
	A. Unpacking and Inspection	
	B. Check Equipment	
	C. Installation and Operation Manual	
VI	Pre-Installation and Boiler Mounting	15-17
VII	Venting	18-32
	A. General Guidelines	18
	B. Field Installation	23
	C. Polypropylene Venting	25
	D. Optional Room Air For Combustion	26
	E. Removing Existing Boiler	28
	F. Multiple Boiler Installation	30
	G. Common Venting Requirements	31
	H. Special Installation Requirements for Massachusetts	30
VIII	Condensate Disposal	33-34
	A. Condensate Trap Installation	
	B. Condensate Neutralizer Installation	
	C. Common Condensate Pump/Sump	
IX	Hydronic Piping	35-42
	A. Required System Pressure	35
	B. Recommended Piping Configuration	35
	C. Factory Supplied Water Manifold	35
	D. Temperature Rise and Boiler Head Loss	36
	E. Standard Installation Requirements	37
	F. Water Quality and Treatments	38
	G. Oxygen Contamination	39
	H. Recommended Piping Configurations	41-42
X	Gas Piping	43-45
	A. Guidelines and Requirements	

TABLE OF CONTENTS

XI	Electrical	46-50
	A. General	46
	B. Power Requirements	46
	C. Boiler Wiring	46
	D. Line Voltage Connection	47
	E. Low Voltage Connection	47
XII	System Startup	51-55
	A. Check Heating System	51-54
	B. Start Boiler	51
	C. Test Safety Limits Controls	54-55
XIII	Service and Maintenance	56-60
	A. Inspect Boiler Area	57
	B. Inspect Boiler Interior	57
	C. Monthly Inspection	57
	D. Annual Inspections and Service	57-59
	E. Restarting After prolong Shutdown	60
XIV	Troubleshooting	61
XV	Repair Parts	62
	APPENDIX A-TABLES	63
	APPENDIX B-FIGURES	64
	APPENDIX C-DEFAULT LIGHT OFF AND MODULATION RPMs	65
	APPENDIX D-INLET, OUTLET WATER AND FLUE OUTLET TEMPERATURE SENSOR RESISTANCE-VOLTAGE CHART	66
	APPENDIX E-VENT AND COMBUSTION AIR PRESSURE DROP DATA	67

I. Hazard Definitions

The following terms are used throughout this manual to bring attention to the presence of hazards of various risk levels, or to important information concerning product life.

It is critical all personnel read and adhere to all information contained in DANGER, WARNING, and CAUTIONS. All DANGERS, WARNINGS, and CAUTIONS are for reference and guidance purpose, and, therefore, do not substitute for strict adherence to applicable jurisdictional and professional codes and regulations.



Indicates an imminent hazardous situation which, if not avoided, will result in death, serious injury or substantial property damage.



Indicates a potentially hazardous situation which, if not avoided, could result in death, serious injury, or substantial property damage.



Indicates a potentially hazardous situation which, if not avoided, may result in moderate or minor injury, or property damage.



Indicates special instructions on installation, operation, or maintenance which are important but not related to personal injury hazards.

II. Read Before Proceeding

A. Local Codes

1. This unit shall be installed in accordance with those installation regulations enforced in the area where the installation is to be made. These regulations shall be carefully followed in all cases. Authorities having jurisdiction shall be consulted prior to installation.
2. This unit must be installed and serviced by a licensed electrician or certified gas supplier.
3. The City of New York requires a Licensed Master Plumber to supervise the installation of this product.
4. The Commonwealth of Massachusetts requires this product to be installed by a Licensed Plumber or Gas Fitter.

B. Warranty

1. This product has a limited warranty, a copy of which is shipped with the unit. It is the responsibility of the installing contractor to ensure all controls are correctly installed and are operating properly.
2. Factory warranty does not apply to units improperly installed or improperly operated.
3. Heat exchanger failure due to lime (scale) build-up in the heat exchanger is not covered under the manufacturer's warranty.
4. It is the responsibility of the customer to ensure water hardness level conforms to Table 15.

C. Shipment Damage

1. Upon receiving the unit, inspect for signs of shipping damages. If the unit has been hit or otherwise mishandled, immediately notify the carrier.
2. Verify total number of factory supplied items, as per the packing slip, with received parts.

D. Connecting Gas Supply Line

1. Connect supply gas line to the boiler via the ground joint union inside the boiler (see Figure 19).
2. Use two wrenches when tightening gas piping at the union connection, one wrench to prevent the boiler gas line from turning.
3. Failure to prevent the gas line from turning could damage gas line components: blower and gas valve.

E. Boiler Operation

1. This appliance **MUST NOT** be installed in any location where gasoline or flammable vapors are likely to be present or, in an environment that contain corrosive contaminants (see Table 4).
2. Do not block or restrict in any way the flow of combustion or ventilation air from or to the boiler.
3. Do not operate unit if any part has been under water. Any appliance that has been under water must be replaced. Water damage to the unit can be extensive and present numerous safety hazards.

F. Gas Leakage (If you detect or smell gas...)

1. Do not try to light any appliance.
2. Do not touch any electrical switch; do not use any phone in the building.
3. Immediately call your gas supplier from a neighbor's phone. Follow the gas supplier's instruction.
4. If you cannot reach your gas supplier, call the fire department.

G. Maintenance

1. To avoid electrical shock, ensure all electrical connections are unpowered before attempting installation or service of electrical components or connections.
2. Lockout all electrical boxes with padlock once power is turned off.
3. To prevent severe burns, allow the boiler to cool before performing maintenance.

H. Freeze Protection Fluids

1. **DONOT USE** automotive antifreeze or Ethylene glycol. Ethylene glycol is toxic and can attack gaskets and seals used in hydronic systems.
2. Use only inhibited propylene glycole solutions, which are specifically formulated for hydronic systems.

I. Product Identification Label

1. A nameplate, in accordance with the ASME code Section IV, is permanently attached to the heat exchanger.
2. To access the nameplate, remove front jacket panel from boiler.

II. Read Before Processing (continued)

J. Factory Test and Inspections

1. Prior to shipment, final air-fuel adjustments are performed by factory trained service personnel on each unit. The factory emissions report is posted on the back of the front jacket panel for troubleshooting and maintenance reference.
2. In addition, the following tests and inspections are performed to ensure the appliance meets our highest safety and performance standards:
 - Operating test
 - Construction inspection
 - Electrical components inspection
 - Crating inspection.

K. Disclaimers and Local Codes

1. Installation must conform to the requirements of the authority having jurisdiction. In the absence of such requirements, installation must conform to the *National Fuel Gas Code, NFPA 54/ANSI Z223.1, and/or CAN/CGA B149* Installation Codes. Where required by the authority having jurisdiction, the installation must conform to the *Standard for Controls and Safety Devices for Automatically Fired Boilers, ANSI/ASME CSD-1*.
2. Installation, start-up, and maintenance of this equipment can be hazardous and requires trained, qualified installers and service personnel. Do not install, operate, service or repair any components of this equipment unless you are qualified and fully understand all requirements and procedures.
3. This instruction manual is an integral part of the product and must be retained by the person in charge of the appliance operation, and service and maintenance.

III. Product Rating, Specifications and Dimensional Data

AMP Series boilers are condensing, high-efficiency, gas-fired, hot water boilers designed for use in forced hot water or heating with indirect domestic hot water heating systems, where supply water temperature does not exceed 210°F. These boilers have special coil type stainless steel heat exchangers, constructed, tested and stamped per

Section IV 'Heating Boilers' of ASME Boiler and Pressure Vessel Code, which provide a maximum heat transfer and simultaneous protection against flue gas product corrosion. These boilers are not designed for use in gravity hot water space heating systems or systems containing significant amount of dissolved oxygen (swimming pool water heating, direct domestic hot water heating, etc.).

Table 1: Ratings

AMP Series AHRI Rating						
Boiler Model	Input (MBH)		Gross Output (MBH)	Net Ratings Water ¹ (MBH)	Thermal Efficiency (%)	Combustion Efficiency (%)
	Min.	Max.				
AMP 1000	200	1000	970	843	97	97
AMP 1250	250	1250	1213	1055	97	97
AMP 1500	300	1500	1455	1265	97	97
AMP 2000	400	2000	1940	1687	97	96.9

¹ Ratings shown are for installations at sea level and elevations up to 2000 ft. at minimum vent length. For high altitude installations above 2000 ft. consult factory.

Table 2: Specifications

Other Specification	Boiler Models			
	AMP 1000	AMP 1250	AMP 1500	AMP 2000
Fuel	Natural Gas	Natural Gas	Natural Gas	Natural Gas
Max. Water Temperature (°F) ¹	210	210	210	210
Max. Working Pressure (psi)	160	160	160	160
Standard Safety Relief Valve (psi) ²	50	50	50	50
Boiler Water Volume (gal.)	10.96	10.96	12.97	16.72
Heat Transfer Area (sq. ft.)	91.6	91.6	109.79	142.0
Approx. Shipping Weight (lb.)	780	780	1050	1150

¹ Boiler will go in hard lockout if temperature exceed 210 °F.

² Optional 30, 60, 75, 100, and 125 psi safety relief valves are available for all models.

III. Product Rating, Specifications and Dimensional Data (continued)

Table 3: Dimensional Data

Dimensions (In.)	Boiler Models			
	AMP 1000	AMP 1250	AMP 1500	AMP 2000
A	45.5	45.5	66-1/8	66-1/8
B	54	54	74-5/8	74-5/8
C	60-1/4	60-1/4	79-3/8	79-3/8
D	34-1/4	34-1/4	34-1/4	34-1/4
E	13-3/8	13-3/8	13-3/8	13-3/8
F	42-3/4	42-3/4	42-3/4	42-3/4
G	36-1/8	36-1/8	36-1/8	36-1/8
H	19-1/4	19-1/4	16-1/2	16-1/2
I	6-7/8	6-7/8	11-7/8	11-7/8
J	14-5/8	14-5/8	13-1/4	13-1/4
K	8-1/2	8-1/2	8-1/2	8-1/2
L	40-1/2	40-1/2	40-1/2	40-1/2
M	44-3/8	44-3/8	44-3/8	44-3/8
N	9-1/4	9-1/4	9-1/4	9-1/4
O	4-7/8	4-7/8	4-7/8	4-7/8
P	13-3/8	13-3/8	13-3/8	13-3/8
Q	6-1/8	6-1/8	8-1/2	8-1/2
R	10-1/8	10-1/8	10-1/8	10-1/8
S	23-1/2	23-1/2	23-1/2	23-1/2
T	32-1/4	32-1/4	32-1/4	32-1/4
Gas Inlet	1	1	1.25	1.25
Supply Pipe Size	3	3	3	3
Return Pipe Size	2-1/2	2-1/2	2-1/2	2-1/2
Air Intake	8	8	8	8
Vent Outlet	8	8	8	8
Condensate Drain	1	1	1	1
Drain Line	3/4	3/4	3/4	3/4
<i>CENTER OF GRAVITY</i>				
X-COG	18-3/4	16-5/8	18-7/8	18-7/8
Y-COG	16-5/8	16-5/8	24-7/8	24-7/8
Z-COG	21-5/8	21-5/8	21-1/4	21-1/4

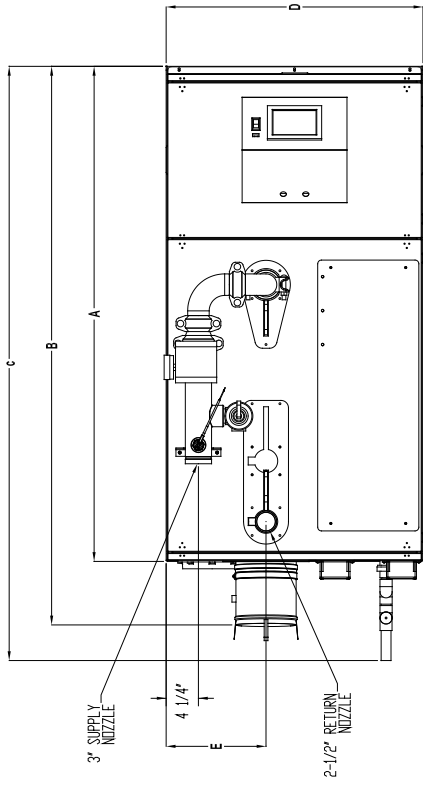

Top View

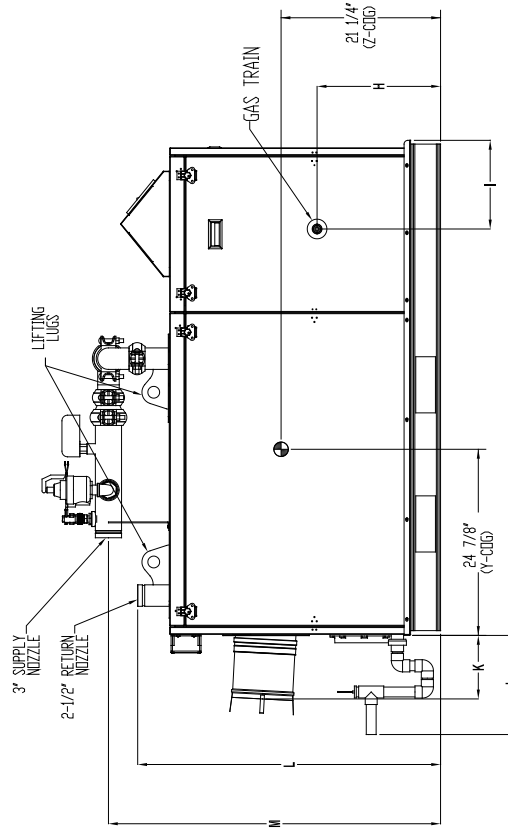

Left Side View

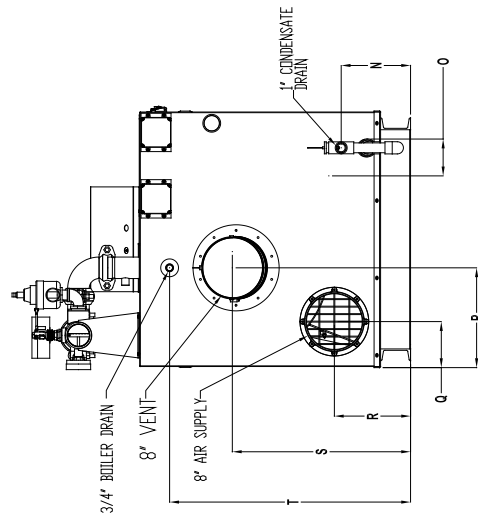

Rear View

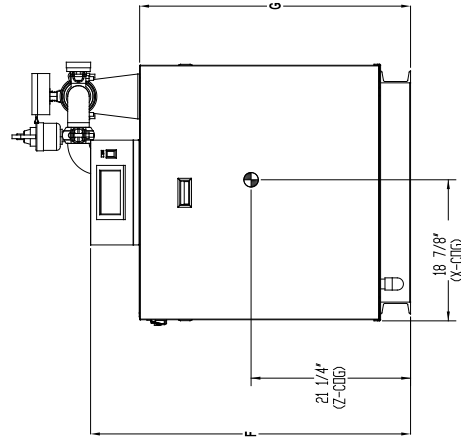

Front View

Figure 1: AMP- MODEL 1000-2000

IV. AMP - Component Identification

1. Communication Interface (Concert Boiler Control™)

The AMP boiler series is equipped with Concert Boiler Control™ display which provides easy access for viewing and adjusting boiler operational parameters, monitoring historical performance characteristics and annunciating boiler alarm/lockout conditions.

2. Main boiler control

It receives and processes input signals from safety switches and sensors to modulate main burner firing rate.

3. Control box

The control box is designed to allow easy access to safety components and PCB boards for service and troubleshooting purposes.

4. ON/OFF switch

The OFF position interrupts power to the unit.

5. Main gas valve

It regulates the flow of gas into the pre-mix burner by sensing negative pressure from the blower.

6. Blower

The blower is designed for pre-mix application and delivers combustion air and gas to the burner at a desired ratio over the modulation range.

7. Bluejet[®] Burner

The high efficiency, low NO_x Bluejet[®] Burner is mounted on the burner door with eight M4 x 10 screws.

8. Ignition electrode

The ionization electrode provides electrical spark for ignition. The ignitor assembly is installed on the burner door with two M4 x 10 torx screws.

9. Flame inspection

A ¾ inch diameter quartz sight glass provides a means of visual inspection of the burner flame condition.

10. Thermal fuse

If the temperature at the burner door reaches over 320 °F, the thermal fuse will interrupt power to the burner. Used to detect dangerous flame blow back and burner door insulation failure.

11. High gas pressure switch

The high gas pressure switch monitors supply gas pressure and shuts off the electrical control circuit when pressure rises above the set point (see Table 21).

12. Low gas pressure switch

The low gas pressure switch monitors supply gas pressure and shuts off the electrical control circuit in the event a low gas pressure condition occurs (see Table 21).

13. Supply water line

Outlet manifold with Victaulic grooved connection conveys supply water from the boiler to the system. Refer to Table 3 for model specific pipe size.

14. Water flow switch

In the event of insufficient water flow the boiler will be shut down by the action of the flow switch. Refer to Table 26 for water flow rate requirements.

IV. AMP - Component Identification (continued)

15. Supply gas line

Provides a means of connection for incoming gas line to the boiler's gas train assembly. See Table 21 for model specific pipe sizes.

16. Return water connection

Conveys return water from the system to the boiler. Refer to Table 3 for model specific pipe size.

17. Boiler Supply water temperature sensor

Main boiler control adjusts the firing rate of the burner based on the supply water temperature and system set point.

18. Low water cut off probe and reset box

The unit comes with an integrated Low Water Cut Off (LWCO) probe and reset box. LWCO safeguards the heat exchanger from inadequate water level. The LWCO has a manual reset button.

19. Temperature and pressure gauge

Provides real time supply water temperature and pressure readings.

20. Relief valve

The safety relief valve protects the heat exchanger from an over pressure condition. Refer to Table 2 for standard factory supplied relief valve sizes and optional sizes for all models.

21. Condensate drain trap

Serves to discharge condensate from heat exchanger while preventing flue gases escaping into condensate drain line.

22. Minimum combustion air proving switch

It ensures adequate combustion air is supplied to the combustion chamber for stable and complete ignition.

23. Blocked vent switch

The blocked vent switch interrupt the control circuit when there is a vent blockage or significant restriction of vent piping.

24. Combustion air intake connection

It provides pathway for combustion air to enter the ignition system by a means of negative pressure (suction) generated by the blower.

25. Exhaust vent connection

The vent pipe conveys combustion products to a safe point of discharge. The unit is equipped with a standard AL-29 4C stainless steel vent connection. Refer to Table 7 for model specific vent connection size.

IV. AMP - Component Identification (continued)

Figure 2: Component Identification

IV. AMP - Component Identification (continued)

Figure 3: Component Identification

V. Unpacking Boiler

A. Unpacking and Inspection

1. Move boiler to approximate installation location.
2. Remove all crate fasteners.
3. Lift and remove outside container.
4. Account for all loose shipped items.
5. Remove boiler cardboard positioning sleeves on shipping skid.
6. The boiler can be moved to its permanent location via a fork lift or an overhead crane attached to the lift lugs.
7. The lift lugs are located next to the inlet/outlet water connections.
8. The boiler can be removed from the pallet using a lift truck from the side, front or rear of the boiler.



Figure 4: Lift Lugs

B. Check Equipment

1. Upon receiving the equipment, check for signs of shipment damage.
2. Pay particular attention to parts accompanying the appliance which may show sign of being hit or otherwise mishandled.
3. Verify total number of pieces shown on packing slip with those actually received. In case there is damage or a shortage, immediately notify the carrier.

C. Installation and Operation Manual

1. The instruction manual enclosed with the unit is an integral part of the product and must be retained by the person in charge of the appliance. Please read the instructions contained in this manual carefully as they provide important information regarding the safe installation, use and servicing of this appliance.



WARNING

Failure to assure the truck forks are long enough to extend at least half way through the boiler's base will result in the boiler tipping off the lift truck and potentially falling. This will result in severe personal injury, death, or substantial property damage.

Do not operate this appliance if any part has been underwater. The possible damage to a flooded appliance can be extensive and present numerous safety hazards. Any appliance that has been underwater must be replaced.

NOTICE

Do not drop, bump, or lean an object against the boiler in order to avoid damaging the heat exchanger or critical components.

VI. Pre-Installation and Boiler Mounting

- A. Installation must conform to the requirements of the authority having jurisdiction or, in the absence of such requirements, to the *National Fuel Gas Code, ANSI Z223.1/NFPA 54, and/or Natural Gas and Propane Installation Code, CAN/CSA B149.1*. Where required by the authority having jurisdiction, the installation must conform to the *Standard for Controls and Safety Devices for Automatically Fired Boilers, ANSI/ASME CSD-1*.
- B. The boiler is certified for installation on non-combustible flooring. Do not install boiler on carpeting.
- C. Provide clearance between boiler jacket and combustible material in accordance with local fire ordinance. Refer to Table 5 for minimum listed clearances from combustible material and recommended service clearance. Recommended service clearance may be reduced but should not be less than clearances to combustible.
- D. Protect gas ignition system components from water (dripping, spraying, rain, etc.) during boiler operation and service (circulator replacement, condensate trap, control replacement, etc.).
- E. Provide combustion and ventilation air in accordance with applicable provisions of local building codes, or: USA - National Fuel Gas Code, ANSI Z223.1/NFPA 54, Air for Combustion and Ventilation; Canada - Natural Gas and Propane Installation Code, CAN/CSA-B149.1, Venting Systems and Air Supply for Appliances.
- F. The boiler should be located so as to minimize the length of the vent system. Ensure air intake pipe termination away from areas that may contaminate combustion air (see Table 4). In particular, avoid areas near chemical products containing chlorines, chlorofluorocarbons, paint removers, cleaning solvents and detergents. Avoid areas containing saw dust, loose insulation fibers, dry wall dust etc.



WARNING

Apply supplied dielectric grease to gasket inside vent connector. Failure to apply the grease could result in flue gas leaks during vent pipe installation or gasket deterioration due to condensate exposure.

Adequate combustion and ventilation air must be provided to assure proper combustion. Install combustion air intake per Section IV "Venting".

Installation of this boiler should be undertaken only by trained and skilled personnel from a qualified service agency. Follow these instructions exactly. Improper installation, adjustment, service, or maintenance can cause property damage, personal injury or loss of life.

Do not change or modify any boiler accessories or parts or jump-out any safety limit devices.

NOTICE

Due to the low water content of the boiler, mis-sizing of the boiler with regard to the heating system load will result in excessive boiler cycling and accelerated component failure.

Thermal Solutions DOES NOT warrant failures caused by mis-sized boiler applications. DO NOT oversize the boiler to the system. Multiple boiler installations greatly reduce the likelihood of boiler oversizing.

Avoid operating this boiler in an environment where sawdust, loose insulation fibers, dry wall dust, etc. are present. If boiler is operated under these conditions, the burner interior and ports must be cleaned and inspected daily to insure proper operation.

Ensure all labels on the boiler are fully visible at all times for the purpose of maintenance and inspections.

VI. Pre-Installation and Boiler Mounting (continued)

G. General.

1. AMP boilers are intended for installation in an area with a floor drain, or in a suitable drain pan to prevent any leaks or safety relief valve discharge resulting in property damage.
2. AMP boilers are not intended to support external piping and venting. All external piping and venting must be supported independently of the boiler.
3. AMP boilers must be installed on a level surface to prevent condensate from backing up inside the boiler. Refer to Table 2 for boiler approximate shipping weight.
4. Boiler Installation:
 - a. For basement installation provide a solid level base such as concrete. Where floor is not level water may be encountered around boiler. Floor must be able to support weight of boiler, water and all additional system components.
 - b. Provide adequate space for condensate piping or a condensate pump, if required.

Table 4: Corrosive Combustion Air Contaminants

Contaminants to Avoid
Spray cans containing chlorofluorocarbons (CFC's)
Permanent wave solutions
Chlorinated waxes/cleaners
Chlorine-based swimming pool chemicals
Calcium chloride used for thawing
Sodium chloride used for water softening
Refrigerant leaks
Paint or varnish removers
Hydrochloric acid/muriatic acid
Cements and glues
Antistatic fabric softeners used in clothes dryers
Chlorine-type bleaches, detergents, and cleaning solvents found in household laundry rooms.
Adhesives used to fasten building products and other similar products
Excessive dust and dirt
Areas likely to have contaminants:
Dry cleaning/laundry areas and establishments
Swimming pools
Metal fabrication plants
Beauty shops
Refrigeration repair shops
Photo processing plants
Auto body shops
Plastic manufacturing plants

VI. Pre-Installation and Boiler Mounting (continued)

H. Combustible material and service clearances

Table 5: Clearances

Combustible Materials							Recommended Service Clearance					
Boiler Model	Front (In.)	Rear (In.)	Right (In.)	Left (In.)	Top (In.)	Vent (In.)	Front (In.)	Rear (In.)	Right (In.)	Left (In.)	Top (In.)	Vent (In.)
AMP 1000	Open	6	6	10	6	6	22	6	24	24	20	18
AMP 1250	Open	6	6	10	6	6	22	6	24	24	20	18
AMP 1500	Open	6	6	10	6	6	22	6	24	24	20	18
AMP 2000	Open	6	6	10	6	6	22	6	24	24	20	18

Figure 5: Recommended Service and Combustible Material Clearances

VII. Venting

A. General Guidelines

1. Listed Vent and Combustion Air Systems

- a. Install vent system in accordance with *National Fuel Gas Code, ANSI Z223.1/NFPA 54* or *Natural Gas and Propane Installation Code, CAN/CSA B149.1* Installation Code for Canada, or, applicable provisions of local building codes.
- b. The AMP is certified as **Category II/IV** boiler. Category II vent is required when common venting multiple units. Refer to Section H "Common Venting Requirements."
- c. The vent pipe serves to expel products of combustion to a safe point of discharge and air intake pipe serves to deliver combustion air from outdoors (Refer part E "Optional Room Air for Combustion Air.") The following vent/combustion system materials are approved for use with the AMP boilers.

WARNING

Failure to vent this boiler in accordance with these instructions could cause products of combustion to enter the building resulting in severe property damage, personal injury or death.

Do not locate vent termination under a deck, or where exposed to prevailing winds.

Do not locate combustion air termination where volatile vapors or other chemicals are present (see Table 4). Severe boiler corrosion and failure will result.

Do not interchange vent systems or materials unless otherwise specified.

Do not apply thermal insulation to vent pipe or fittings.

Do not use a barometric damper; draft hood or vent damper with this boiler.

Atmospheric venting is prohibited.

Table 6: Vent/Air Intake Options

Vent System		Material	Pipe Direction
Standard-Factory Supplied	Vent	AL 29-4C	Vertical or Horizontal
	Air Intake	PVC/ Galvanized steel	Vertical or Horizontal
Option 1	Vent	Polypropylene	Vertical or Horizontal
	Air Intake	PVC, Galvanized steel	Vertical or Horizontal
Option 2	Vent	CPVC	Vertical or Horizontal
	Air Intake	PVC/Galvanized steel	Vertical or Horizontal

Note: For "Option 1" refer to Table 10 for polypropylene vent adapter.

2. Requirements

- a. Do not exceed maximum vent/combustion air lengths listed in Table 7. Vent and combustion air length restrictions are based on equivalent length of vent and combustion air pipe (total length of straight pipe plus equivalent length of fittings). Table 8 lists equivalent lengths for fittings.
- b. Do not include vent/combustion air terminal in equivalent feet calculations. Use vent/combustion air equivalent length worksheet provided in Table 9.
- c. See Table 5 for recommended clearance to service and combustible materials.

WARNING

Moisture and ice may form on surface around vent termination.

To prevent deterioration, surface must be in good repair (sealed, painted, etc.).

Do not allow low spots in the vent where condensate may pool.

Use specified vent and combustion air pipe diameters.

All vent and combustion air pipe must be sealed and airtight.

Alteration of the boiler vent connection is prohibited.

VII. Venting (continued)

Table 7: Vent and Combustion Air Pipe Sizes and Equivalent Lengths

Boiler Model	Combustion Air Length			Vent Length		
	Pipe Dia. (ft.)	Minimum (ft.)	Maximum (ft.)	Pipe Dia. (ft.)	Minimum (ft.)	Maximum ¹ (ft.)
AMP 1000	8	0	100	8	3	100
AMP 1250						
AMP 1500						
AMP 2000						
¹ Up to 200 feet maximum when drawing combustion air from inside.						
Applies to all listed vent/combustion air system options.						
NOTE: Contact factory for assistance for changing RPM for Max. vent applications.						

Table 8: Vent System and Combustion Air System Component Equivalent Length

Component	Equivalent Length (ft)
Nominal Diameter	8
90° Elbow	10
45° Elbow	10

Table 9: Vent and Combustion Air Equivalent Length Calculation Worksheet

Component	Combustion Air					Vent				
	Equivalent Length Per Piece	x	Quantity	=	Subtotal Equivalent Length	Equivalent Length Per Piece	x	Quantity	=	Subtotal Equivalent Length
Straight Pipe		x		=	A					D
90° Elbow		x		=	B					E
45° Elbow		x		=	C					F
	Combustion Air Total Equivalent Length			=		Vent Total Equivalent Length				
Notes:										
1. Total equivalent length cannot exceed maximum equivalent length shown in Table 7.										
2. Use elbow equivalent lengths provided in Table 8.										
3. Combustion air and vent terminations do not count towards total equivalent length.										

Table 10: Recommended Polypropylene Vent Pipe Adapter and Suppliers

Boiler Model	Vent Diameter (in.)	Centrotherm Part # (Innoflue PP System)	Duravent Part # (Polypro PP System)
AMP 1000	8	ISSA0808	8PPS-08PVCM-8PPF
AMP 1250	8	ISSA0808	8PPS-08PVCM-8PPF
AMP 1500	8	ISSA0808	8PPS-08PVCM-8PPF
AMP 2000	8	ISSA0808	8PPS-08PVCM-8PPF

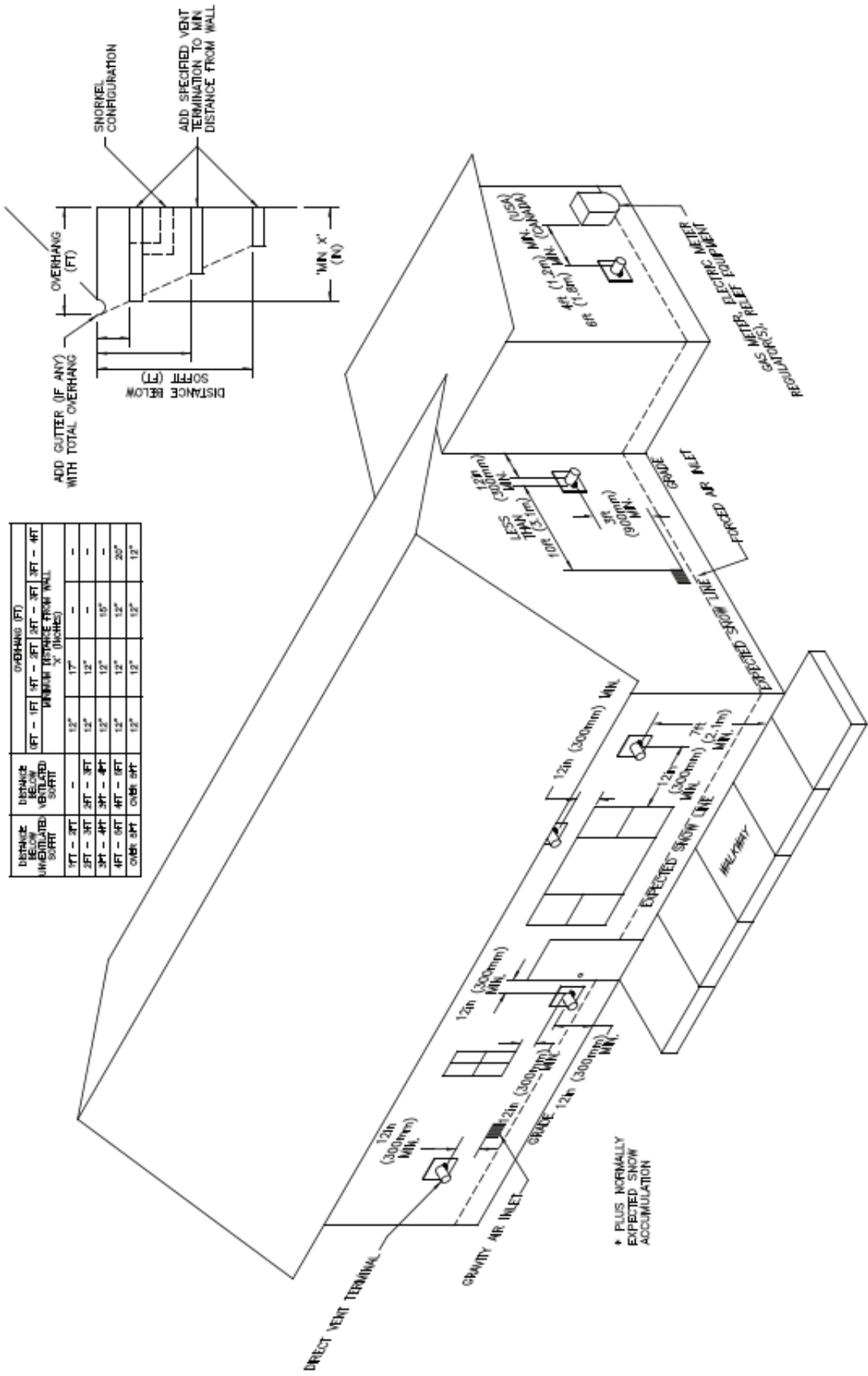

Figure 6: Location of Vent Terminal Relative to Windows, Grades, Overhangs, Meters and Forced Air Inlets Two-Pipe System Vent Terminal (shown). Two-Pipe System Air Intake Terminal (Not Shown)

VII. Venting (continued)

- d. Enclose vent passing through occupied or unoccupied spaces above boiler with material having a fire resistance rating at least equal to the rating of adjoining floor or ceiling.
- e. Slope horizontal vent pipe minimum 1/4 in/ft (21 mm/m) downward towards the boiler to allow condensate to drain freely.
[Les chaudières de catégories I, II et IV doivent présenter des tronçons horizontaux dont la pente montante est d'au moins 1/4 po par pied (21 mm/m) entre la chaudière et l'évent.]
- f. If possible, slope horizontal combustion air pipe minimum 1/4 in/ft (21 mm/m) downward towards terminal. If not, slope towards boiler.
- g. Use noncombustible 3/4 in. pipe strap to support horizontal runs and maintain vent location and slope while preventing sags in pipe. Do not restrict thermal expansion or movement of vent system. Maximum support spacing 4 ft. (1.2 m). Avoid low spots where condensate may pool. Do not penetrate any part of the vent system with fasteners.

[Les instructions d'installation du système d'évacuation doivent préciser que les sections horizontales doivent être supportées pour prévenir le fléchissement. Les méthodes et les intervalles de support doivent être spécifiés. Les instructions doivent aussi indiquer les renseignements suivants: Les chaudières de catégories II et IV doivent être installées de façon à empêcher l'accumulation de condensat: etsi nécessaire, les chaudières de catégories II et IV doivent être pourvues de dispositifs d'évacuation du condensat]

- h. For multiple boiler installations with vertical roof terminals, separate vent pipes from multiple boilers may be piped through a common conduit for chase so that one roof penetration may be made.

3. Vent and Combustion Air Terminals

Install venting system components on exterior of building only as specifically required by these instructions (see Figure 6).

- a. Use only listed vent/combustion air terminals.
 - i. Horizontal Sidewall Venting: Use coupling for vent and 90° elbow pointed down for combustion air as shown in Figure 7. If using room air for combustion, use 90° elbow or tee for vent.
 - ii. Vertical Roof Venting: Use coupling on vent and two 90° elbows turned downwards for combustion air as shown in Figures 8 and 9.
- b. Maintain correct clearance and orientation between vent and combustion air terminals.
 - i. Space centerlines of vent and combustion air terminals minimum 12 in. (300 mm) apart. 36 in. (915 mm) spacing is recommended.
 - ii. If possible, locate vent and combustion air terminals on the same wall to prevent nuisance shutdowns. If not, boiler may be installed with roof vent terminal and sidewall combustion air terminal.
 - iii. When installed on the same wall, locate vent terminal at same height or higher than combustion air terminal.
- c. Locate bottom of vent and combustion air terminals at least 12 in. (300 mm) [18 in. (460 mm) in Canada] above the normal snow line and at least 12 in. (300 mm) above grade level.
- d. Locate vent and combustion air terminals at least 12 in. (300 mm) from any door, window, or gravity inlet into the building.
- e. Do not install vent terminal directly above windows or doors.
- f. Locate bottom of vent terminal at least 3 ft. (900 mm) above any forced air inlet located within 10 ft. (3.0 m).
- g. If window and/or air inlet is within 4 ft. (1.2 m) of an inside corner, maintain at least 6 ft. (1.8 m) spacing between terminal and adjoining wall of inside corner.
- h. Locate bottom of vent terminal at least 7 ft. (2.1 m) above a public walkway.

VII. Venting (contined)...

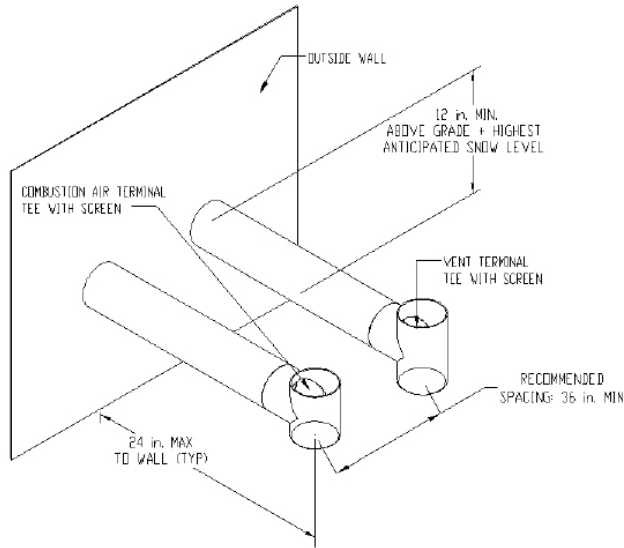

Figure 7: Sidewall Terminations

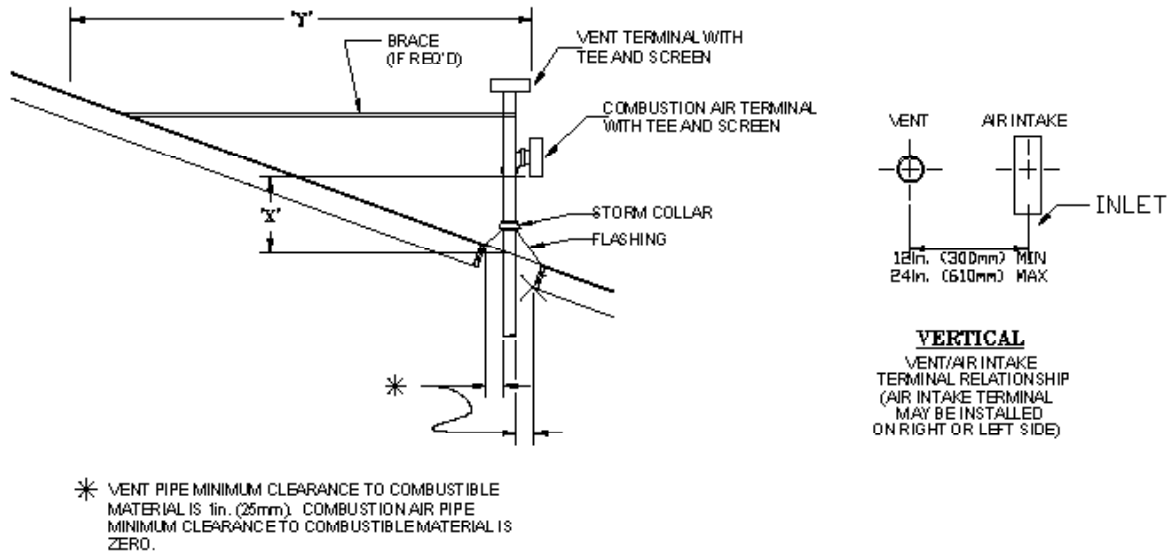

Figure 8: Vertical Terminations with Sloped Roof

- i. Maintain minimum clearance of at least 4 ft. (1.2 m) [3 ft. (900 mm) in Canada] horizontally between vent terminal and gas meters, electric meters, regulators, and relief equipment. Do not install vent terminal above or below this equipment.
- j. Do not locate the vent terminal under decks or similar structures.
- k. Top of terminal must be at least 24 in. (600 mm) below ventilated eaves, soffits, and other overhangs. In no case may the overhang exceed 48 in. (1200 mm). Where permitted by the authority having jurisdiction and local experience, the terminal may be located closer to unventilated soffits. The minimum vertical separation depends upon the depth of the soffit. See Figure 6 for details.

VII. Venting (continued)

- l. Maintain minimum 12 in. (300 mm) horizontal spacing between vent terminal and a building corner.
- m. Under certain conditions, water in the flue gas may condense, and possibly freeze, on objects around the terminal including on the structure itself. If these objects are subject to damage by flue gas condensate, they should be moved or protected.
- n. If possible, install the vent and combustion air terminals on a wall away from the prevailing wind. Reliable operation of this boiler cannot be guaranteed if terminals are subjected to winds in excess of 40 mph (64 km/hr).
- o. Do not locate combustion air terminal in areas that might contain combustion air contaminants, such as near swimming pools.
- p. For multiple boiler installations with horizontal wall terminals, maintain minimum 12 in. (300 mm) horizontal distance between adjacent boiler vent terminals. Maintaining greater spacing is recommended to avoid frost damage to building surfaces where vent terminations are placed.
- q. For multiple boiler installations with vertical roof terminals, maintain minimum 12 in. (300 mm) horizontal distance between adjacent boiler vent terminals.
- b. Design the air intake system to allow 3/8" (9.5mm) of thermal expansion per 10 ft. (3m) of CPVC/PVC pipe. Runs of 20 ft. (6.1m) or longer that are restrained at both ends must be an offset.
- c. CPVC combustion air pipe joints must be cleaned with primer and glued with cement. Follow all manufacturer instructions and drawings when preparing pipe ends for joining and using the primer and the cement.
- d. Size and cut wall openings such that a minimal clearance is obtained and to allow easy insertion of vent pipe.

B. Field Installation

1. Factory Supplied Vent and Combustion air connections

- a. A factory installed 8.0" diameter cast aluminum ring provides a means for air intake connection.
- b. A factory installed vent connector provides a means for vent connection.
- c. Vent and combustion air intake pipe must be supported to allow uniform flow of combustion air and flue gas.

2. System Assembly

- a. Plan venting system to avoid possible contact with plumbing or electrical wires. Start at boiler's vent connector and work towards vent termination.



Failure to follow these instructions could cause products of combustion to enter the building, resulting in severe property damage, personal injury, or death.

Use CPVC vent components within any interior space where air cannot circulate freely, including through vertical or horizontal chase ways, inside a stud wall, in closets, and through wall penetrations.

The use of cellular core PVC (ASTM F891), cellular core CPVC or Radel (polyphenolsulfone) is prohibited.

All condensate that forms in the vent must be able to drain back to the boiler.



Do not exceed maximum vent/combustion air system length.

Refer to Appendix E for equivalent feet ratio for sizing the vent or air intake pipe diameter.

VII. Venting (continued)

3. Vertical Roof Termination

a. Standard Two-Pipe Termination

i. Vent Piping

- Install fire stops where vent passes through floors, ceilings or framed walls. The fire stop must close the opening between the vent pipe and the structure.
- Whenever possible, install vent straight through the roof.
 - Size roof opening to maintain minimum clearance of 1 in. (25 mm) from combustible materials.
 - Extend vent pipe to maintain minimum vertical distance for expected snow accumulation. Provide brace as required.
 - Install storm collar on vent pipe immediately above flashing. Apply Dow Corning Silastic 732 RTV Sealant or equivalent between vent pipe and storm collar to provide weather-tight seal.

ii. Combustion Air Piping

- If possible, locate combustion air termination in the same roof location as the vent termination to prevent nuisance boiler shutdowns. Combustion air terminal may be installed closer to roof than vent. Alternatively, boiler may be installed with vertical roof vent terminal and sidewall combustion air terminal.
- Size roof opening to allow easy insertion of combustion air piping and allow proper installation of flashing and storm collar to prevent moisture from entering the structure.
 - Use appropriately designed vent flash when passing through roofs. Follow flashing manufacturers' instructions for installation.
 - Extend combustion air pipe to maintain minimum vertical and horizontal distance of 12 in (300 mm) from roof surface.

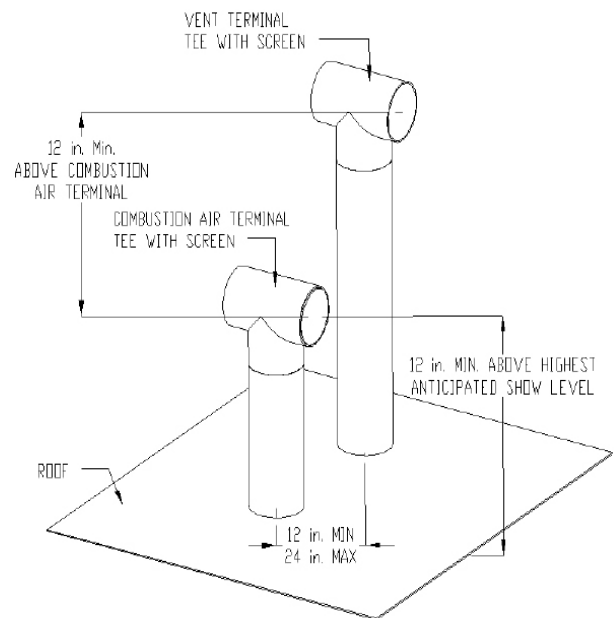

Figure 9: Vertical Termination



NOTICE

Methods of securing and sealing terminals to the outside wall must not restrain the thermal expansion of the vent pipe.

Exterior run to be included in equivalent vent/combustion air lengths.

Vertical Venting and combustion air roof penetrations (where applicable) require the use of roof flashing and storm collar, which are not supplied with boiler, to prevent moisture from entering the structure.

Examine all components for possible shipping damage prior to installation.

All condensate that forms in vent must be able to drain back to the boiler.

The venting system must be free to expand and contract and must be supported in accordance with installation instructions included by the original component manufacturers, whenever applicable. Polypropylene pipe sections must be disengaged 1/4 to 5/8 in. (6 mm to 16 mm) per joint to allow for thermal expansion.

VII. Venting (continued)

4. Horizontal Sidewall Vent Termination

- a. Standard Two-Pipe Termination
 - i. Vent Termination
 - Make end of terminal will fit into female end of any of the listed stainless vent systems.
 - Apply a heavy bead of silicone to the male end of the terminal before inserting it into the last piece of pipe. Orient the terminal so that the seam in the terminal is at 12:00.
 - Smooth the silicone over the seam between the terminal and the last piece of pipe, applying additional silicone if necessary to ensure a tight seal.
 - Allow the silicone to cure per the silicone manufacturer's instructions before operating the boiler.
 - ii. Combustion Air Termination
 - Use a 90° elbow directed downward..
 - Install a screen in the inlet terminal. Use a screen having 1/2 in. x 1/2 in. (13 mm x 13 mm) mesh.

5. Vertical Vent Termination

- a. Standard Two-Pipe Termination
 - i. Vent Termination
 - Use the vent terminal connection supplied with boiler. Follow manufacturer's instructions to attach terminal to vent system.
 - ii. Combustion Air Termination
 - Install vertical combustion air terminal. Vertical combustion air terminal consists of a 180° bend (comprised of two 90° elbows) as shown in Figure 10.
 - Install screen in the combustion air terminal. Use a screen having 1/2 in. x 1/2 in. (13 mm x 13 mm) or larger mesh.



NOTICE

The joint between the terminal and the last piece of pipe must be outside of the building. Use 90° elbow or tee for horizontal sidewall vent termination when using room air for combustion.

VII. Venting (continued)

C. Polypropylene Venting

1. Running Flexible Polypropylene Vent (Liner) Through Unused Chimney Chase

- a. It is the responsibility of the installing contractor to procure polypropylene vent system pipe and related components.
- b. All listed polypropylene vent system manufacturers comply with the requirements of *ULC-S636-08* 'Standard for Type BH Gas Venting Systems'. For Canadian installation, polypropylene vent must be listed as a *ULC-S636* approved system.
- c. Flexible polypropylene pipe must be treated carefully and stored at temperatures higher than 41 degrees F.
- d. When flexible polypropylene pipe (liner) is used for combustion air supply to a boiler, the pipe (liner) can be installed in vertical or horizontal position.
- e. Follow manufacturer instructions regarding application/listing, permits, minimum clearances to combustibles, and installation details (proper joint assembly, pipe support and routing, gasket and fitting installation, optional tooling availability/usage, routing through masonry chimney for combustion product venting or combination of combustion product venting and combustion air supply).
- f. When using a masonry chimney as a passageway for flexible polypropylene pipe, the chase must be structurally sound and free of any debris or obstructions.
- g. To prevent condensate pooling and damage to vent, offsets (bend) cannot exceed 45°. Multiple offsets are allowed in a chase.



Asphyxiation Hazard. Vent systems made by listed PP vent system manufacturers rely on gaskets for proper sealing. When this type of vent system is used, take the following precautions:

Make sure that gasket is in position and undamaged in the female end of the pipe.

Make sure that both male and female pipes are free of damage prior to assembly.

Only cut vent pipe as permitted by the vent manufacturer in accordance with their instructions. When pipe is cut, cut end must be square and carefully de-burred prior to assembly.

Use locking band clamps at all vent pipe joints.

Flexible polypropylene vent must be installed only in an unused chimney. A chimney, either single or multiple flue type, is considered unused when one of the flues is being used for any appliance venting, or when one of the multiple flues is being used for appliance venting. The flexible vent installation is not permitted through any of adjacent flues.

Do not bend or attempt to install flexible pipe if it has been stored at ambient temperature below 41 F. This will cause material to become brittle and will lead to cracks, resulting in flue gas leaks.

Do not install flexible polypropylene pipe at an angle greater than 45 degrees from vertical plane when used for combustion product venting. Failure to do so will result in improper condensate drainage towards the boiler and possible subsequent vent pipe blockage.

VII. Venting (continued)

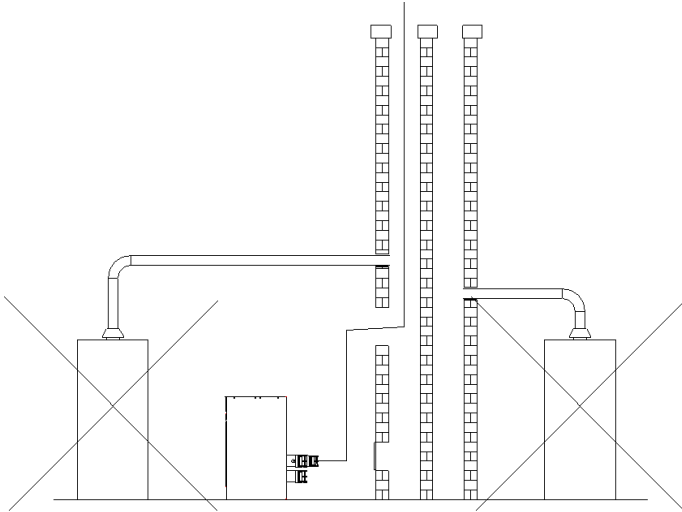

WARNING

DO NOT mix vent systems of different types or manufacturers. Failure to comply could result in severe personal injury, death, or substantial property damage.

Do not insulate polypropylene vent pipes. Excessive heat could cause premature vent pipe failure.

NOTICE

Pressure drop for flexible polypropylene line is 20 % greater than from rigid pipe. Multiply measured flexible polypropylene liner length by 1.2 to obtain equivalent length.

Maximum equivalent vent length of flexible polypropylene liner is 48 ft. (14.6 m).

Installation of a polypropylene vent system should adhere to the vent manufacturer's installation instructions supplied with the vent system.

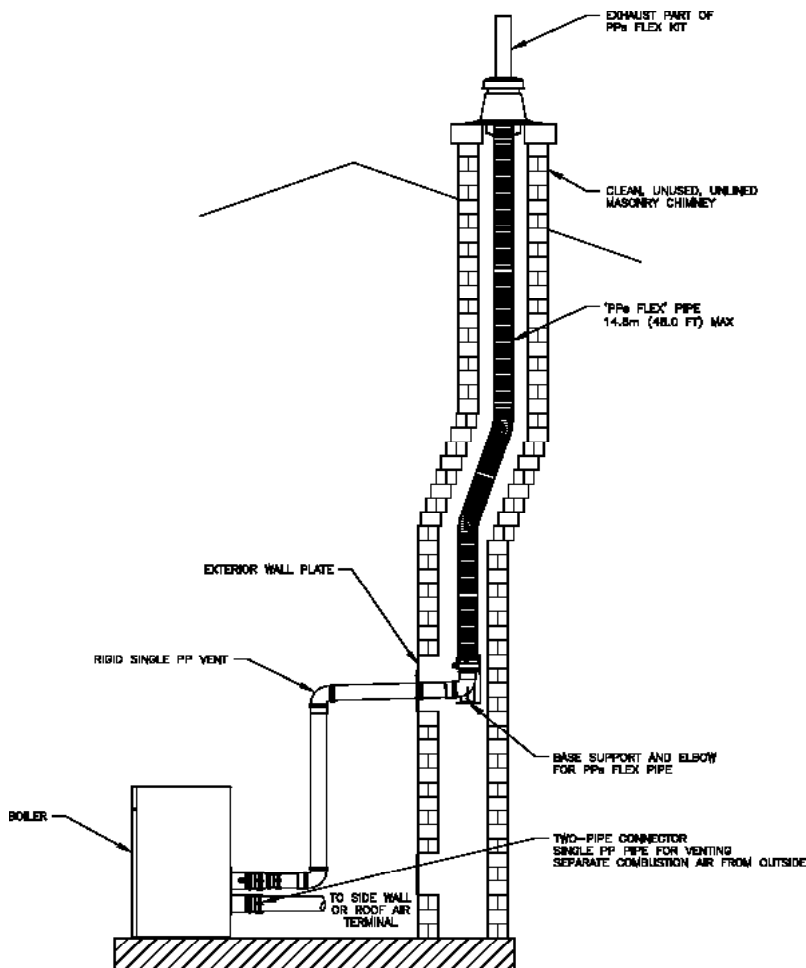

Figure 10: Flexible Vent in Masonry Chimney with Separate Combustion Air Intake

VII. Venting (continued)

D. Optional Room Air for Combustion

1. General Guidelines

- a. Room air is optional for commercial applications. Follow the requirements in this section when air for combustion is supplied from boiler room.
- b. Avoid combustion air contaminants in the boiler room. Permanently remove any contaminants found in the boiler room. If contaminants cannot be removed, do not use room air for combustion.

2. Outdoor Openings to Boiler Room

- a. **Provide combustion and ventilation air to the boiler room or enclosure.** Follow the National fuel Gas Code, *ANSI Z223.1*, or, in Canada, Installation Code for Gas Burning Appliances and Equipment, *CGA Standard B149 Code* as well as all applicable local codes. Use one of the following two methods.

- b. **Two Permanent Openings Method:** Provide two permanent openings, one within 12 in. (300 mm) of the top of the enclosure and one within 12 in. (300 mm) of the bottom of the enclosure. Openings must communicate directly, or by ducts, with the outdoors or spaces that freely communicate with the outdoors. Ensure the ducts to communicate with outdoors have the same cross-sectional area as the free area of the opening to which they are connected.

- i. Direct communication or through vertical ducts: **minimum free area of each opening shall be 1 in.²/4000 Btu/hr (550 mm²/kW)** of total input rating of all appliances within the enclosure.
- ii. Horizontal ducts: minimum free area of each opening shall be **1 in.²/2000 Btu/hr (1100 mm²/kW)** of total input rating of all appliances within the enclosure.

- c. **One Permanent Opening Method:** Provide one permanent opening, commencing within 12 in. (300 mm) of the top of the enclosure.

The opening shall communicate through a vertical or horizontal duct to the outdoors or spaces that freely communicate with the outdoors and shall have a minimum free area of the following:

- i. **1 in.²/3000 Btu/hr (700 mm²/kW)** of total input rating of all appliances located within the enclosure.
- ii. Not less than the sum of the areas of all vent connectors in the space.

- d. **Motorized Louvers or Dampers: Motorized** louvers or dampers must be interlocked with the boiler to allow ignition and firing of the burner only when louvers are in the fully-open position. Wire the interlock to the Auto Reset External Limit connections. See Section VIII "Electrical".

3. Terminations

- a. For standard horizontal sidewall terminations, see Figure 7 and 8. For vertical roof terminations, see Figure 9 and 10.
- b. When using room air for combustion, use 90° elbow or tee for sidewall vent termination.

E. Removing Existing Boiler

When an existing boiler is removed from a common venting system, the common venting system is likely to be too large for proper venting of the remaining appliances. At the time of removal of an existing boiler, the following steps should be performed with each appliance remaining connected to the common venting system. Make sure the appliance are not in operation while carrying out these steps.



Sources of combustion air contaminants, including chlorines, chlorofluorocarbons (CFC's), petroleum distillates, detergents, volatile vapors or other chemicals must not be present in the boiler room. If any of these contaminants is present, severe boiler corrosion and failure will result.

VII. Venting (continued)

1. Seal any unused openings in the common venting system.
 2. Visually inspect the venting system for proper size and horizontal pitch and determine there is no blockage or restriction, leakage, corrosion, or other deficiencies which could cause an unsafe condition.
 3. Insofar as is practical, close all exterior doors and windows, and all doors between the space when the appliances remain connected to the common venting system and other spaces of the building. Turn on any exhaust fans, such as range-hoods and bathroom exhausts, so they will operate at maximum speed. Do not operate a summer exhaust fan. Close fireplace dampers.
 4. Place in operation the appliance being inspected. Follow the Lighting (or Operating) Instructions. Adjust thermostat so appliance will operate continuously.
 5. Test for spillage at the draft hood relief opening after 5 minutes of main burner operation. Use the flame of a match or candle, or smoke from a cigarette, cigar or pipe.
 6. After it has been determined that each appliance connected to the common venting system properly vents when tested as outlined above, return doors, windows, exhaust fans, fireplace dampers and any other gas burning appliance to their previous conditions of use.
 7. Any improper operation of the common venting system should be corrected so the installation conforms with the *National Fuel Gas Code, ANSI Z223.1/NFPA 54* and/or the *Natural Gas and Propane Installation Code, CAN/CSA B149.1*. Resizing of any portion of the common venting system, should be done in accordance with the *National Fuel Gas Code, ANSI Z223.1/NFPA 54* and/or the *Natural Gas and Propane Installation Code, CAN/CSA B149.1*.
2. Inspecter de façon visuelle le système d'évacuation pour déterminer la grosseur et l'inclinaison horizontale qui conviennent et s'assurer que le système est exempt d'obstruction, d'étranglement, de fuite, de corrosion et autres défaillances qui pourraient présenter des risques.
 3. Dans la mesure du possible, fermer toutes les portes et les fenêtres du bâtiment et toutes les portes entre l'espace où les appareils toujours raccordés au système d'évacuation sont installés et les autres espaces du bâtiment. Mettre en marche les sècheuses, tous les appareils non raccordés au système d'évacuation commun et tous les ventilateurs d'extraction comme les hottes de cuisinière et les ventilateurs des salles de bain. S'assurer que ces ventilateurs fonctionnent à la vitesse maximale. Ne pas faire fonctionner les ventilateurs d'été. Fermer les registres des cheminées.
 4. Mettre l'appareil inspecté en marche. Suivre les instructions d'allumage. Régler le thermostat de façon que l'appareil fonctionne de façon continue.
 5. Faire fonctionner le brûleur principal pendant 5 min ensuite, déterminer si le coupe-tirage déborde à l'ouverture de décharge. Utiliser la flamme d'une allumette ou d'une chandelle ou la fumée d'une cigarette, d'un cigare ou d'une pipe.
 6. Une fois qu'il a été déterminé, selon la méthode indiquée ci-dessus, que chaque appareil raccordé au système d'évacuation est mis à l'air libre de façon adéquate. Remettre les portes et les fenêtres, les ventilateurs, les registres de cheminées et les appareils au gaz à leur position originale.
 7. Tout mauvais fonctionnement du système d'évacuation commun devrait être corrigé de façon que l'installation soit conforme au *National Fuel Gas Code, ANSI Z223.1/NFPA 54* et (ou) aux codes d'installation *CAN/CSA-B149.1*. Si la grosseur d'une section du système d'évacuation doit être modifiée, le système devrait être modifié pour respecter les valeurs minimales des tableaux pertinents de l'appendice F du *National Fuel Gas Code, ANSI Z223.1/NFPA 54* et (ou) des codes d'installation *CAN/CSA-B149.1*.

Au moment du retrait d'une chaudière existante, les mesures suivantes doivent être prises pour chaque appareil toujours raccordé au système d'évacuation commun et qui fonctionne alors que d'autres appareils toujours raccordés au système d'évacuation ne fonctionnent pas:

1. Sceller toutes les ouvertures non utilisées du système d'évacuation.

VII. Venting (continued)

G. Multiple Boiler Installation

1. Vent Piping Terminations

- a. Multiple boiler vent terminations are shown in Figure 11.
- b. Each individual boiler must have its own vent pipe and vent terminal. Refer to Paragraphs A through F (as applicable) for individual boiler vent guidelines and options.
- c. For horizontal sidewall terminations, maintain at least 12 in. (300 mm) minimum horizontal distance between any adjacent individual boiler vent terminations. Additional horizontal spacing between any adjacent individual boiler vent terminations as well as extending the distance from building surfaces to vent termination end are recommended to avoid frost damage to building surfaces where vent terminations are placed.
- d. Individual boiler sidewall vent terminals must be placed at least 12 in. (300 mm) [18 in. (460 mm) in Canada] above the ground plus the expected snow accumulation.
- e. Multiple individual boiler vertical vent pipes may be piped through a common conduit or chase so that one roof penetration may be made.
- f. For vertical roof terminations, maintain at least 12 in. (300 mm) minimum horizontal distance between adjacent individual boiler vent terminations.

2. Combustion Air Piping

- a. Multiple boiler combustion air terminations are shown in Figure 11.
- b. Each individual boiler must have its own combustion air pipe and terminal. Refer to Paragraphs A through F (as applicable) for individual boiler combustion air guidelines and options.
- c. Do not exceed the individual boiler maximum combustion air pipe length listed in Table 8.
- d. If possible, locate vent and combustion air terminals for an individual boiler on the same wall to prevent nuisance shutdowns. If not, an individual boiler may be installed with a roof vent terminal and sidewall combustion air terminal.



Asphyxiation Hazard. No common manifold venting (vent piping and vent terminals) is permitted.



Installing multiple individual boiler vent terminations too close together may result in combustion product water vapor condensation on building surfaces, where vent terminations are placed, and subsequent frost damage. To avoid/minimize frost damage, extend the distance from building surfaces to vent termination end and increase the horizontal distance between adjacent vent terminations.

VII. Venting (continued)

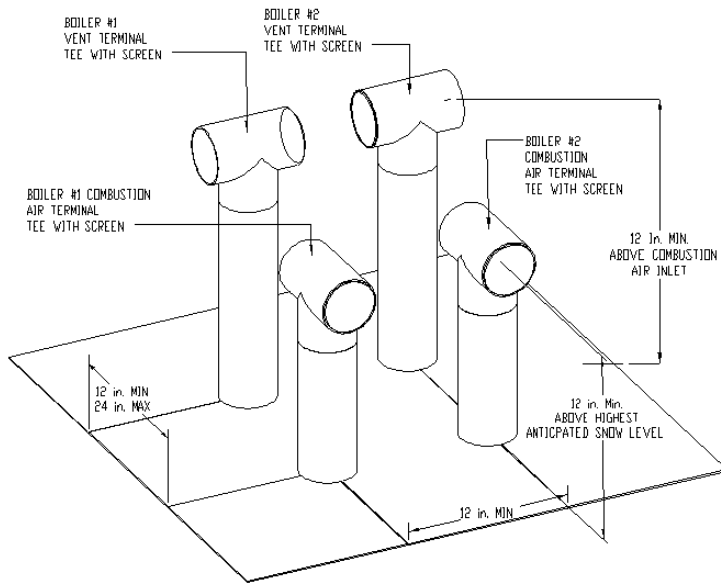

Figure 11: Multiple Boiler Direct Termination

H. Common Venting Requirements

1. Category II Venting

- a. Category II venting is an engineered system and shall be designed by a qualified vent manufacturer using accepted engineering practices and “Approved” by the local authority.
 - i. Common venting with other appliances is prohibited.
 - ii. Vertical vent is recommended. Other horizontal and vertical arrangements may be acceptable if proven by the vent manufacturers design calculations.
 - iii. To prevent backflow through the boiler, vent systems shall be designed to maintain a **negative 0.001 in. w.c. to negative 0.1 in. w.c. draft** at all times from the minimum to the maximum firing rate measured at the outlet of the boiler.
 - iv. A mechanical draft fan may be required to maintain the required negative draft.
 - v. A vent damper may be required as part of the engineered system.
 - vi. It is recommended that a Carbon Monoxide detector be installed and interlocked to the boiler. Consult your local jurisdiction for additional requirements.



WARNING

Thermal Solutions takes no responsibility for vent systems that create issues and or affect the performance of the boiler.

Improper Installation of a Category II vent system resulting in positive pressure in the vent system can result in flue gas spillage and carbon monoxide emissions, causing severe personal injury or death.

VII. Venting (continued)

I. Special Installation Requirements for Massachusetts

- A. For all sidewall horizontally vented gas fueled equipment installed in every dwelling, building or structure used in whole or in part for residential purposes and where the sidewall exhaust vent termination is less than seven (7) feet above grade, the following requirements shall be satisfied:
1. If there is no carbon monoxide detector with an alarm already installed in compliance with the most current edition of NFPA 720, NFPA 70 and the Massachusetts State Building Code in the residential unit served by the sidewall horizontally vented gas fueled equipment, a battery operated carbon monoxide detector with an alarm shall be installed in compliance with the most current edition of NFPA 720, NFPA 70 and the Massachusetts State Building Code.
 2. In addition to the above requirements, if there is not one already present, a carbon monoxide detector with an alarm and a battery back-up shall be installed and located in accordance with the installation requirements supplied with the detector on the floor level where the gas equipment is installed. The carbon monoxide detector with an alarm shall comply with 527 CMR, ANSI/UL 2034 Standards or CSA 6.19 and the most current edition of NFPA 720. In the event that the requirements of this subdivision can not be met at the time of the completion of the installation of the equipment, the installer shall have a period of thirty (30) days to comply with this requirement; provided, however, that during said thirty (30) day period, a battery operated carbon monoxide detector with an alarm shall be installed in compliance with the most current edition of NFPA 720, NFPA 70 and the Massachusetts State Building Code. In the event that the sidewall horizontally vented gas fueled equipment is installed in a crawl space or an attic, the carbon monoxide detector may be installed on the next adjacent habitable floor level. Such detector may be a battery operated carbon monoxide detector with an alarm and shall be installed in compliance with the most current edition of NFPA 720, NFPA 70 and the Massachusetts State Building Code.
 3. A metal or plastic identification plate shall be permanently mounted to the exterior of the building at a minimum height of eight (8) feet above grade directly in line with the exhaust vent terminal for the horizontally vented gas fueled heating appliance or equipment. The sign shall read, in print size no less than one-half (1/2) inch in size, **"GAS VENT DIRECTLY BELOW. KEEP CLEAR OF ALL OBSTRUCTIONS"**.
 4. A final inspection by the state or local gas inspector of the sidewall horizontally vented equipment shall not be performed until proof is provided that the state or local electrical inspector having jurisdiction has granted a permit for installation of carbon monoxide detectors and alarms as required above.
- B. EXEMPTIONS: The following equipment is exempt from 248 CMR 5.08(2)(a) 1 through 4:
1. The equipment listed in Chapter 10 entitled "Equipment Not Required To Be Vented" in the most current edition of NFPA 54 as adopted by the Board; and
 2. Product Approved sidewall horizontally vented gas fueled equipment installed in a room or structure separate from the dwelling, building or structure used in whole or in part for residential purposes.
- C. When the manufacturer of Product Approved sidewall horizontally vented gas equipment provides a venting system design or venting system components with the equipment, the instructions for installation of the equipment and the venting system shall include:
1. A complete parts list for the venting system design or venting system; and
 2. Detailed instructions for the installation of the venting system design or the venting system components.
- D. When the manufacturer of a Product Approved sidewall horizontally vented gas fueled equipment does not provide the parts for venting flue gases, but identifies "special venting systems", the following shall be satisfied:
1. The referenced "special venting system" instructions shall be included with the appliance or equipment installation instructions; and
 2. The "special venting systems" shall be Product Approved by the Board, and the instructions for that system shall include a parts list and detailed installation instructions.
- E. A copy of all installation instructions for all Product Approved sidewall horizontally vented gas fueled equipment, all venting instructions, all parts lists for venting instructions, and/or all venting design instructions shall remain with the appliance or equipment at the completion of the installation.

VIII. Condensate Disposal

A. Condensate trap installation

1. Locate the condensate trap assembly shipped loose with this appliance.
2. Install the condensate trap on the rear of the appliance in the lower left-hand corner as shown in Figure 12.
3. Connect condensate float switch lead wires to terminals 75 and 76 on PCB 1.
4. Prior to operating the unit--fill the trap with water to prevent flue gas emission into the boiler room.

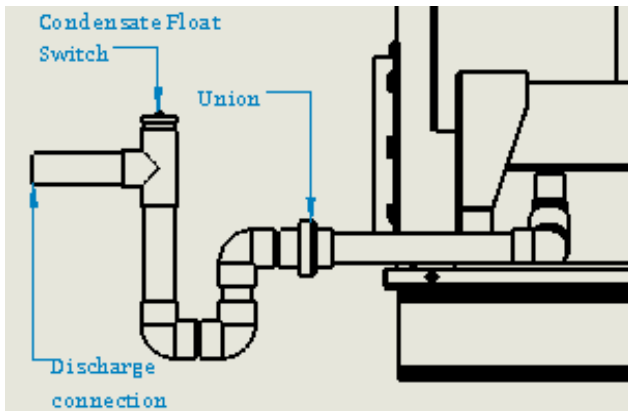

Figure 12: Condensate Trap Assembly

5. Note the following when disposing of the condensate:
 - a. Condensate is slightly acidic, typical pH around 3.5 - 4.5. Do not route the drain line through areas that could be damaged by leaking condensate.
 - b. Use continuous Teflon, high temperature silicone tubing, or other tubing material compatible with flue gas condensate for condensate piping.
 - c. Do not route or terminate the condensate drain line in areas subject to freezing temperatures.
 - d. If the point of condensate disposal is above the trap, a condensate pump is required to move the condensate to the drain. Select a condensate pump approved for use with condensing appliance—and equipped with an overflow switch.
 - e. Do not attempt to substitute another trap for one provided with the boiler.
 - f. Slope condensate drain pipe at least 1/8" per foot in the direction of discharge.



NOTICE

Do not crimp condensate drain lines or reduce drain line inner diameter size.

Do not manifold boiler condensate and vent drains together.

Consult local authorities regarding disposal of flue gas condensate into public waste water system.

Do not use metallic pipe or fittings for condensate drain line.

6. Refer to Table 11 "Maximum Condensate Flow" when sizing condensate drain line, pump and neutralizer kit.

Table 11: Maximum Condensate Flow

Boiler Model	¹ Maximum Condensate Flow (GPH)
AMP 1000	75
AMP 1250	86
AMP 1500	102
AMP 2000	134
¹ Maximum condensate flow rate.	

VIII. Condensate disposal (continued)

B. Condensate Neutralizer Installation

1. Some jurisdictions may require that the condensate be neutralized before being disposed of. Follow local codes pertaining to condensate disposal.
2. A condensate neutralizer kit is available from factory as optional equipment. Refer to Table 12 for size specific part number . Follow local codes and instructions enclosed with the kit for condensate neutralizer installation.
3. Limestone chips will get coated by neutral salts (product of chemical reaction between limestone and acidic condensate) and lose neutralizing effectiveness over time. Therefore, periodic condensate neutralizer maintenance and limestone chip replacement must be performed.

Table 12: Condensate Newutralizer Kit

Boiler Model	Condensate Neutralizer Kit, PN	Condensate Neutralizer, Refill Kits
AMP 1000	107860-01	107886-01
AMP 1250	107860-02	107886-02
AMP 1500	107860-02	107866-02
AMP 2000	107860-02	107866-02

C. Common Condensate pump/Sump

1. A common condensate pump/sump may be used. Run separate piping from each condensate drain to the sump. A common drain may be used to discharge condensate from the sump.
2. If a common sump is used, individual drain lines should be constructed, using material listed above, such that one drain cannot back feed into another drain.
3. Do not manifold boiler condensate and vent drains together.



WARNING

Failure to fill the condensate trap with water prior to boiler start-up could cause flue gas to enter the building, resulting in personal injury or death.

Failure to install the condensate drain in accordance with the above instructions could cause flue gas to enter the building, resulting in personal injury or death.



NOTICE

Boiler condensate is corrosive. Route condensate drain line in a manner such that any condensate leakage will not cause property damage.

If the condensate line is obstructed in any way, the float switch will prevent the appliance from firing.

Some jurisdictions may require that condensate be neutralized prior to disposal.

The condensate drain trap should be flushed with clean water as part of your boiler maintenance schedule to remove any debris that might have accumulated.

IX. Hydronic Piping

A. Piping System To Be Employed

AMP boilers are designed to operate in a closed loop pressurized system. Minimum pressure in the boiler must be 14.5 psi (100 kpa). For proper operation of the unit, the water flow rate through the boiler must remain within the limits given in Table 13.

B. Recommended Piping Configuration

It is required that boiler piping systems utilize Primary/Secondary or fixed or variable flow configuration (see Figures 15-18).

For Primary/Secondary piping configuration, isolate the unit from the system via a closely spaced tees (12 inches or 4 pipe diameter) to ensure sufficient flow is maintained through the boiler.

1. The flow rate through the primary loop is maintained by installer provided circulator.
2. Other piping configurations may be used. However, it is the responsibility of the installer to size circulator(s) that could overcome boiler's heat exchanger and system pressure drops.
3. Inadequate flow through the boiler can cause high limit shutdowns, hot spots and localized boiling which could severely damage the heat exchanger.
4. For possible piping configuration, see section "Hydronic Piping Configuration". These piping arrangements can be used either for space heating-only applications or space heating

C. Factory Supplied Water Manifold

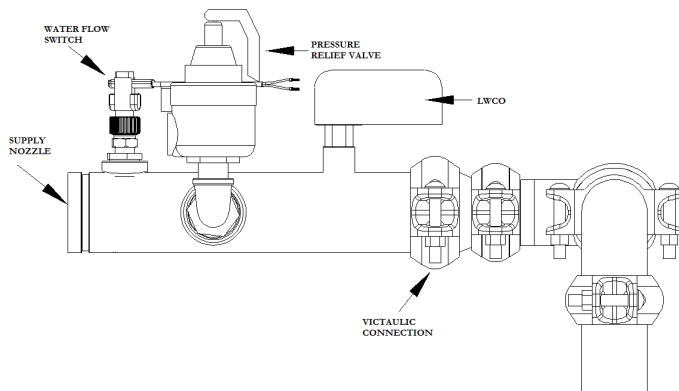

Figure 13: Factory Supplied Manifold



Failure to properly pipe boiler may result in improper operation and damage to the boiler or structure.

Install boiler so that the gas ignition system components are protected from water (dripping, spraying, rain, etc.) during appliance operation and service (circulator replacement, etc.).

Oxygen contamination of the boiler water will cause corrosion of iron and steel boiler components, and can lead to boiler failure. Thermal Solutions' Standard Warranty does not cover problems caused by oxygen contamination of boiler water or scale (lime) build-up caused by frequent addition of water.

Do not fill boiler with softened water to prevent chloride contamination.

Installation is not complete unless a safety relief valve is installed in the trapping located on the water manifold or the supply piping.

Failure to maintain the flow through boiler within specified limits could result in erratic operation or premature boiler failure.

Where it is not possible to install a separate boiler loop, the system circulator must be sized to ensure that the flow through boiler stays within the defined parameters to prevent overheating when the boiler is fired at its full rated input. Install a flow meter to measure the flow, or fire the boiler at full rate and ensure the boiler delta T does not exceed 45F.

It is required that boiler piping systems utilize Primary/Secondary configurations. The use of other piping configurations could result in improper building and system flow rates leading to boiler high limit shutdowns and poor system performance.

Maintain 1" (24mm) clearance around all uninsulated hot water pipes.

IX. Hydronic Piping (continued)

D. Temperature Rise and Heat Exchanger Head Loss

- The AMP heat exchanger add pressure drop which must be accounted in your system design.

Table 13: Temperature Rise

Boiler Model	Delta 20 °F		Delta 25 °F		Delta 30 °F		Delta 35 °F		Delta 40 °F		Delta 45 °F		Delta 50 °F		Delta 55 °F	
	Req. GPM	Head Loss (ft)	Req. GPM	Head Loss (ft)	Req. GPM	Head Loss (ft)	Req. GPM	Head Loss (ft)	Req. GPM	Head Loss (ft)	Req. GPM	Head Loss (ft)	Req. GPM	Head Loss (ft)	¹ Req. GPM	Head Loss (ft)
AMP 1000	97	11	78	6.7	65	5.2	55	4.1	49	3.8	43	3.8	40	2.5	35	2.0
AMP 1250	121	16	97	11	81	7.2	69	6.1	61	5.2	54	3.8	50	3	44	2.8
AMP 1500	146	17	116	10.5	97	8.4	83	6	73	5	65	4.2	60	3.4	53	3.0
AMP 2000	194	19	155	13.4	129	10	111	8.3	97	6.7	86	5	80	4.2	71	4.0

Notes: Required Flow = $\text{Output} \times 1000 / (500 \times \Delta T)$, where flow rate is in GPM, output is in MBH, and ΔT is in °F. Outputs for specific boiler models are provided in Table 1. Using boiler antifreeze will result in increased fluid density and may require larger circulators.

¹ Absolute minimum flow rate.

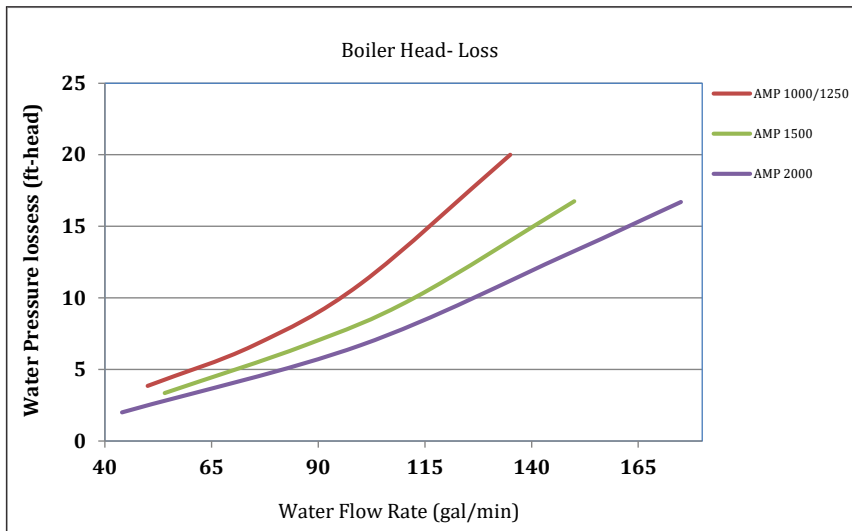

Figure 14: Boiler Head Loss

- For systems with glycol mixture, the flow rate specified in Table 13 will increase as specified in Table 14 due to the extra frictional loss introduced by the glycol. Size pump accordingly.
- Strictly follow glycol manufacturer's guidelines and recommendations when adding glycol in the heating system.

Table 14: Increase Flow For Glycol System

¹ System Glycol Concentration (%)	Increase Flow, GPM (%)
50	24
30	14

¹ Total system water volume includes expansion tank(s) and reservoirs.

IX. Hydronic Piping (continued)

E. Standard Installation Requirements

1. **Safety Relief Valve (Required)** -The safety relief valve is shipped loose with the boiler and must be installed in the location shown in Figure 13.
 - a. The safety relief valve must be installed with spindle in vertical position. Installation of safety relief valve must comply with ASME Boiler and Pressure Vessel Code, Section IV. For standard and optional safety relief valve for specific boiler model refer to Table 2.
 - b. If the safety relief valve is to be replaced, the replacement valve must have a relief capacity equal or exceeding the minimum relief valve capacity shown on the heat exchanger ASME plate. Also, when replacing the safety relief valve, verify the temperature and pressure gauge meets ASME requirements for the replacement safety relief valve.
 - c. Pipe the safety relief valve discharge to a location where hot water or steam will not create hazard or property damage if the valve discharges. The end of the discharge pipe must terminate in an untreated pipe.
 - d. If the safety relief valve is not piped to a drain, it must terminate at least 6 in. (150mm) above the floor. Do not run safety relief valve discharge pipe through an area prone to freezing. The termination of discharge piping must be in an area where it will not become plugged by debris.
2. **Flow Switch (Required)** -The flow switch is factory provided. A flow switch is required in lieu of manual reset low water cutoff (LWCO) for forced circulation coil-type water boilers to prevent overheating and heat exchanger failure in accordance with requirements of ASME Boiler and Pressure Vessel Code, Section IV, and ANSI/ASME CSD-1 latest edition, "Controls and Safety Devices for Automatically Fired Boiler".



Burn Hazard. Safety relief valve discharge shall be piped in such a way to prevent or eliminate potential burn risk.

DO NOT pipe in any area where freezing could occur.

DO NOT install any shut-off valves, plugs or caps.

Consult local codes for proper discharge pipe arrangement.

Observe a minimum of 1/2 inch (12 mm) clearance around all uninsulated hot water piping.

3. **Circulator (Required)** -Near boiler pump is required to maintain minimum flow requirements for proper operation of the boiler. It is the responsibility of the installer to size and install near boiler pump(s). Refer to Table 13 for boiler specific head losses.
4. **Expansion Tank (Required)** -If this boiler is replacing an existing boiler with no other changes in the system, the old expansion tank can generally be reused. If the expansion tank must be replaced, consult the expansion tank manufacturer's literature for proper sizing.
5. **Fill Valve (Required)** -Either manual (recommended) or automatic fill valve may be used. However, if automatic refill is employed, a water meter must be added to evaluate the makeup water volume taken after initial fill and eliminate any water leakage as early as possible.
6. **Automatic Air Vent (Required)** -At least one automatic air vent is required. Manual vents will usually be required in other parts of the system to remove air during initial fill.
7. **Y-strainer (Recommended)** -A Y-strainer or equivalent strainer removes heating system debris from the hydronic systems and protects boiler heat exchanger from fouling.

IX. Hydronic Piping (continued)

Install the strainer downstream of the full port isolation valve at the inlet side of the circulator for ease of service.

8. **Flow Control Valve (Strongly Recommended)**-
The flow control valve prevents flow through the system unless the circulator is operating. Flow control valves are used to prevent gravity circulation in circulator zone systems through zones that are not calling for heat.
9. **Isolation Valves (Strongly Recommended)**--
Isolation valves are useful when the boiler must be drained, as they will eliminate having to drain and refill the entire system.
10. **Drain Valves (Required)**--A factory installed 3/4" NPT drain valve and connection is provided with the unit.

F. Water Quality and Treatments

1. Sanitary units will be subject to chemical effects when they are filled with water. The quality of water used in the heating system is essential for the successful operation and longevity of the product. A successful water treatment plan will help to maintain efficiency, reduce the frequency of repair and/or replacement, and extend the working life of the boiler and other system equipment. If left untreated, poor water quality could cause a number of problems including, but not limited to, oxidation, scaling, corrosion, and fouling.
2. Since the condition of water varies from location to location, it is impossible to prescribe a one-zone-fits-all treatment plan for the system water. In order to develop an effective water treatment plan, it will be necessary to gain knowledge of the impurities dissolved in the water. Once all the impurities are identified, the proper treatment plan can be established. Therefore, it will be essential to obtain the expertise of a qualified industrial water treatment professional to establish a treatment plan. In addition, a periodic testing/sampling plan should be developed. The intent of the plan should be:
 - a. Ensure the protection of the boiler and system equipment.
 - b. Prevent any unforeseen system failure
 - c. Provide information for use in addressing the water quality.
 - d. To confirm the proper concentration of chemicals.



The AMP boiler heat exchanger is made from stainless steel tubular double coil having relatively narrow waterways. Once filled with water, it will be subject to the effects of corrosion. Failure to take the following precautions to minimize corrosion, and overheating could result in severe boiler damage.

Before connecting the boiler, insure the system is free of impurities, grease, sediment, construction dust, sand copper dust, flux and any residual boiler water additives. Flush the system thoroughly and repeatedly, if needed, with clear water mixed with concentrated rinse agent to remove these contaminants completely.

Iron oxide (red oxide sludge Fe_2O_3) is produced by oxygenation. To minimize any oxygen presence in the system, the system must be air free and leak tight. Do not connect the boiler to radiant tubing without an oxygen barrier. Using automatic water refill is not recommended. However, if such refill is employed, a water meter must be added to evaluate the make up water volume taken after initial fill and eliminate any water leakage as early as possible.

Black oxide sludge (magnetite Fe_3O_4) forms as the result of continuous electrolytic corrosion in any system not protected by an inhibitor.

Scale deposit is made up of lime scale contained in most distributed water and settles over the warmest surfaces of boiler heat exchanger causing subsequent overheating and eventual failure.

Refer to "Service and Maintenance" for recommended heating system water treatment products (corrosion/scale inhibitors, cleaners etc) and their suppliers.

IX. Hydronic Piping (continued)

3. Excessive water hardness causes a lime build-up inside heat exchanger tubes. To minimize corrosion effects, adhere to water hardness level given in Table 15. Refer to Table 16 and 17 for recommended Corrosion/Scale inhibitors removal agents, suppliers and treatment options.
 - a. If the water hardness is higher than 15 gpg, softener should be used.
 - b. Before connecting the boiler, insure the system is free of impurities, grease, sediment, construction dust, dust, and any residual boiler water additives. .
 - c. Flush the system thoroughly and repeatedly, if needed, with clear water mixed with concentrated rinse agent to remove these contaminants completely.

G. Oxygen Contamination

1. Continuous addition of make-up water will constantly add oxygen to the system and lead to corrosion. Block oxide sludge (magnetic, Fe_2O_3) forms as a result of continuous electrolytic corrosion in any system unprotected by an inhibitor.
2. To minimize oxygen presence in the system, all system leaks must be repaired immediately. DO NOT connect the boiler to radiant tubing without an oxygen barrier.
3. There are many possible causes of oxygen contamination such as:
 - a. Addition of excessive make-up water as a result of system leak
 - b. Absorption through open tanks and fittings.
 - c. Oxygen permeable materials in the distribution system
4. In order to insure long product life, oxygen sources must be eliminated. This could be accomplished by taking the following measures:
 - a. Repairing system leaks to eliminate the need for addition of make-up water.
 - b. Eliminate and/or repair fittings which allow oxygen absorption.
 - c. Use of non-permeable materials in the distribution system.
 - d. Isolating the boiler from the system water using an intermediate heat exchanger.
 - e. Using properly designed air elimination devices in water piping.



WARNING

When using Glycol products, all Glycol manufacturers' requirements, including rust inhibitors, must be adhered to. Maximum 50 % Glycol.

Thermal Solutions' Standard Warranty does not cover boiler failure caused by oxygen contamination of boiler water or scale build-up.

IX. Hydronic Piping (continued)

Table 15: Water Hardness Level

Boiler Model	Hardness level, 4-12 GPG	Hardness level, 12-15 GPG
AMP 1000	99 gpm	132 gpm
AMP 1250	99 gpm	132 gpm
AMP 1500	110 gpm	183 gpm
AMP 2000	138 gpm	285 gpm
If system contains aluminum components, pH must be less than 8.5.		

Table 16: Recommended Corrosion/Scale Inhibitors Removal Agent Suppliers

Corrosion/Scale Inhibitors and Recommended Suppliers				
Producers	Fernox	Sentinel	Sotin	ADEY
Inhibitors	Protector F1/Alphi 11	X100, X500	Sotin 212	MC1+
Noise reducer		X200		
Universal Cleaner	Restorer	X300		
Sludge remover	Protector F1, Cleaner F3	X400	Sotin 212	
Antifreeze	Alphi 11	X500		
Tightness		Leak Sealer F4		

Table 17: Treatment Type

Treatment Type	Preventive	Corrective
Producer F1	X	
X100	X	X
X200	X	
X300		
X400		X
X500	X	X
Alphi 11	X	
Leaker Sealer F4	X	
Sotin 212		X
MC1+	X	

IX. Hydronic Piping (continued)

H. Recommended Piping Configurations

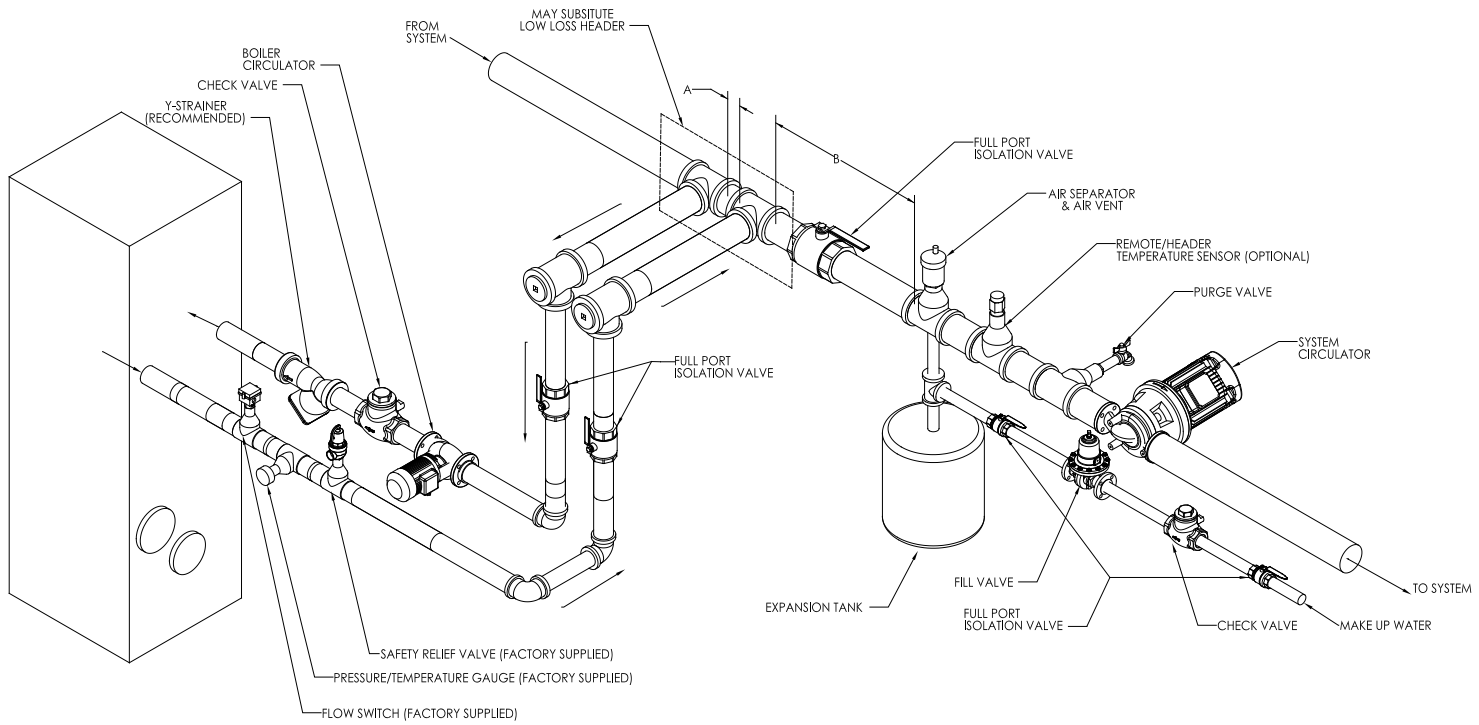

NOTES:
 1. This is a suggested piping configuration. It is the installer's responsibility to confirm with local codes and ordinances for additional requirements.
 2. Pressure relief valve setting shall not exceed pressure rating of any component in the system.
 3. Boiler Pump must be sized to overcome pressure drop across entire boiler loop.

A. NO FURTHER APART THAN 12 INCHES OR FOUR PIPE DIAMETERS, WHICHEVER IS SMALLER
 B. AT LEAST 18" OF STRAIGHT PIPE FOR CONVENTIONAL AIR SCOOP.

Figure 15: Single Boiler-Recommended-Primary/Secondary Piping

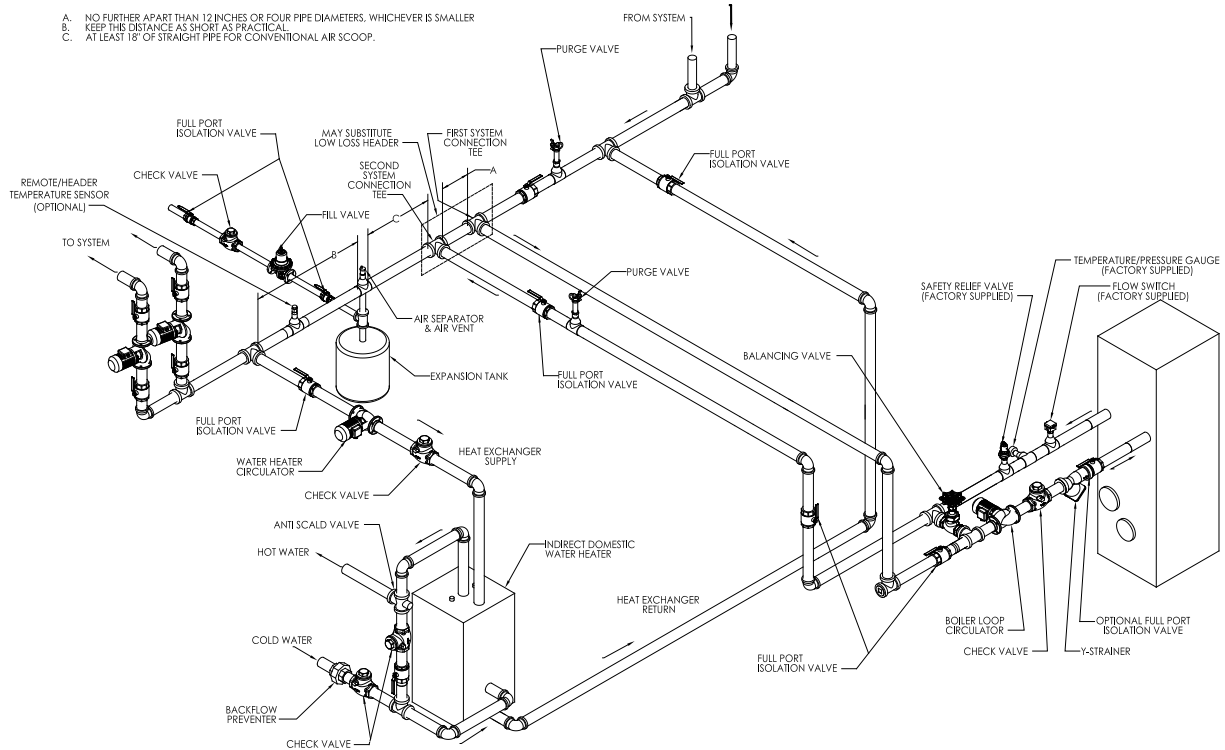

NOTES:
 1. This is a suggested piping configuration. It is the installer's responsibility to confirm with local codes and ordinances for additional requirements.
 2. Pressure relief valve setting shall not exceed pressure rating of any component in the system.
 3. Boiler Pump must be sized to overcome pressure drop across entire boiler loop.

Figure 16: Primary-Secondary Piping with Domestic Hot Water

IX. Hydronic Piping (continued)

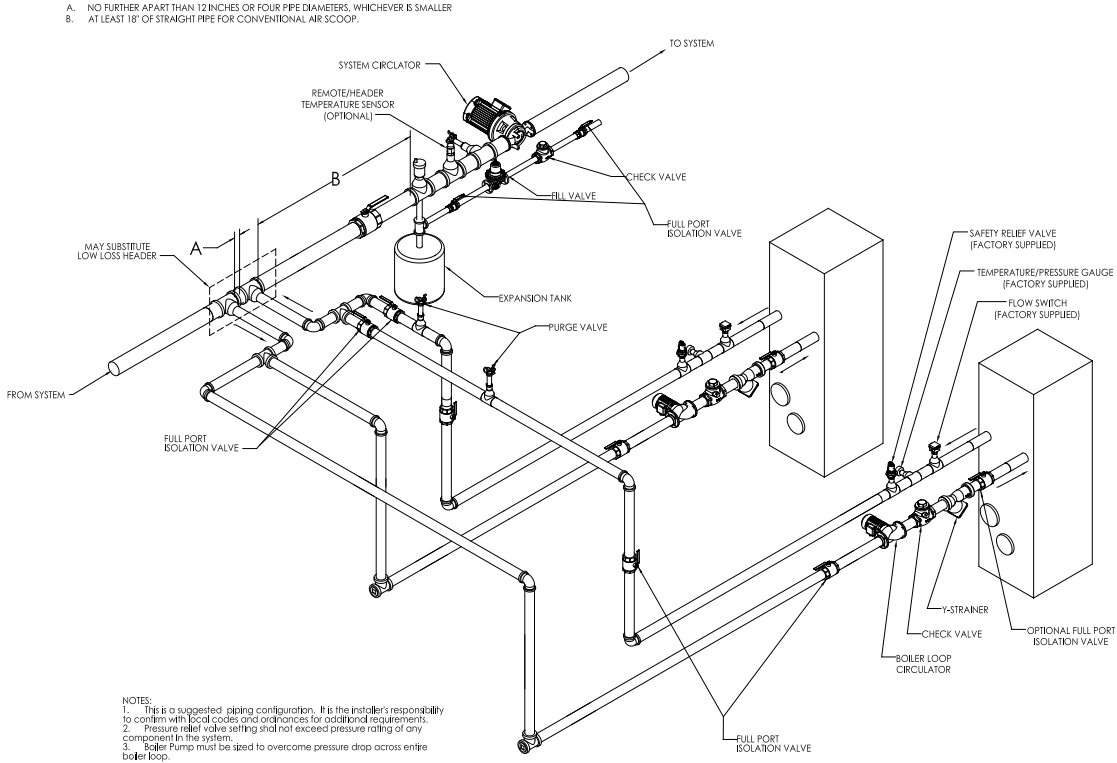

Figure 17: Multiple Boiler Primary/Secondary Piping

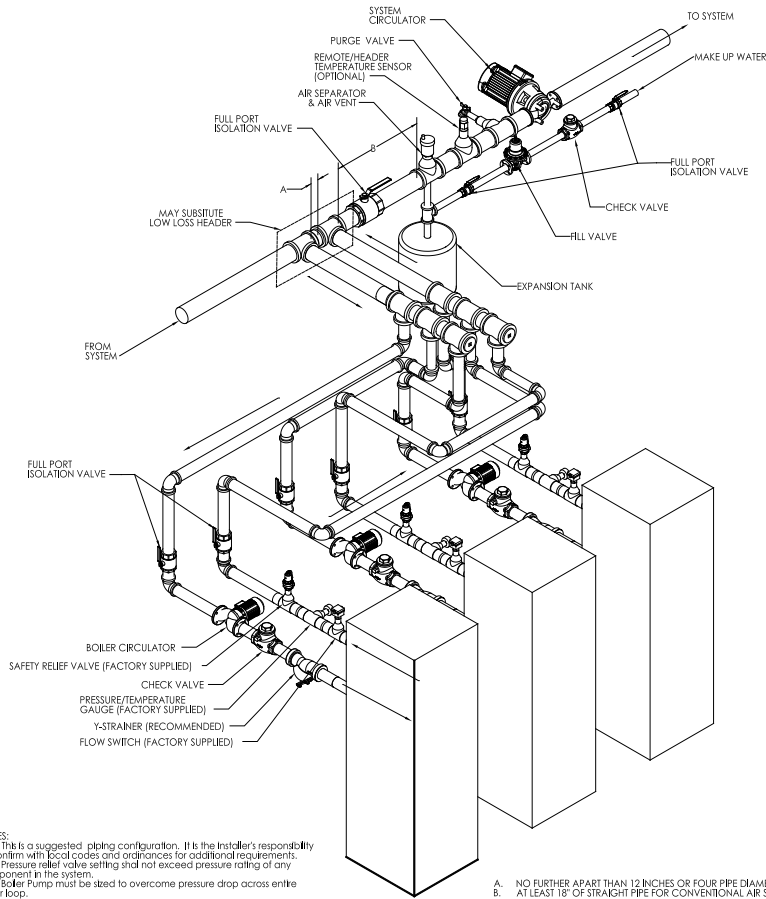

Figure 18: Multiple Boiler Piping with common Header

X. Gas Piping

A. Guidelines and Requirements

All installation must conform to the *National Fuel Gas Code ANSI Z223.1/NFPA54*, and/or local codes. In Canada, installation confirm to the latest edition of *CSA B149.1 National Gas and Propane Gas Installation Code*, and /or local codes.

Safe operation of the appliance requires properly sized gas supply piping. Design gas piping system to provide adequate gas supply to the boiler. Account for existing and expected future gas utilization equipments such as water heater and cooking equipments.

1. First verify that the appliance is supplied with the type of gas specified on the rating plate.
2. Account pressure drop from point of delivery to boiler. Maximum allowable system pressure is ½ psig. Refer to Table 21 for model specific gas pressures and gas connection sizes.
3. If the gas supply pressure is higher than the value listed in Table 18, additional field supplied pressure regulator will be required.
4. Length of piping and number of fittings. Refer to Table 18 (natural gas) for maximum capacity of Schedule 40 pipe. Table 18 lists equivalent pipe length for standard fittings.
5. Gas piping systems for gas specific gravity of 0.60 can be sized directly from Table 18 and gas with a specific gravity of 1.5 can be sized from Table 19, unless authority having jurisdiction specifies a gravity factor be applied. For other specific gravity, apply gravity factor from Table 19. If exact specific gravity is not shown choose next higher value.
6. A sediment trap must be provided upstream of the main gas valve (see Figure 19).
7. All threaded joints should be coated with piping compound resistant to action of liquefied petroleum gas.
8. The appliance and its gas connection must be leak tested before placing it in operation.
9. To protect the boiler gas valve, testing over 1/2 psig (3.4 kPa), boiler and its individual shutoff valve must be disconnected from gas supply piping.

For testing at 1/2 psig (3.4 kPa) or less, isolate boiler from gas supply piping by closing boilers's individual manual shutoff valve.

10. Locate leaks using approved combustible gas non-corrosive leak detector solution.
11. The incoming gas pressure can be measured at the pressure tapping on the manual ball valve.
12. If the high or low gas pressure switch tripped, it must be manually reset before the boiler can be restarted.
13. Gas piping shall be supported by fixed hangers or stands and not by the appliance.
14. Purge all air from gas lines.
15. Install manual shutoff valve in accordance with state and local requirements.

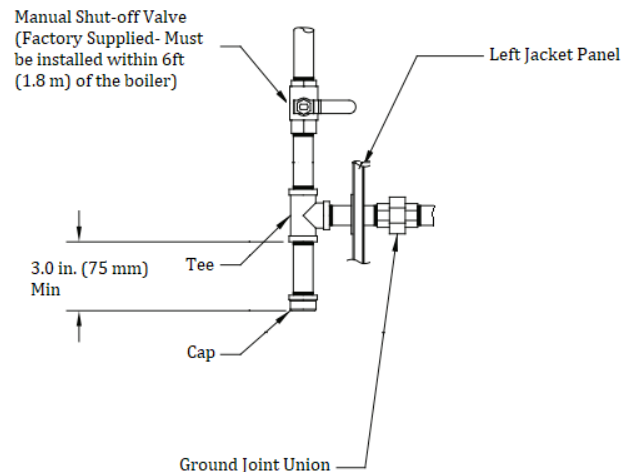

Figure 19: Recommended Gas Piping



NOTICE

Use lock-up type gas pressure regulator when low and high gas pressure switches are installed. Older or non-lock-up type regulators may result in nuisance lockouts on gas pressure drops or spikes.

To AMP and all other appliances must be firing at maximum capacity to properly measure the inlet supply pressure.

X. Gas Piping (continued)

Table 18: Maximum Capacity of Schedule 40 Black Pipe in CFH* (Natural Gas) For Gas Pressures of 1/2 psi (3.4 kPa) or Less

Inlet Pressure 14.0 in wc (3.4 kPa) or less; 0.3 in wc (0.07 kPa) Pressure Drop											
Nominal Pipe Size, In.	Inside Diameter, In.	Length of Pipe, Ft.									
		10	20	30	40	50	60	70	80	90	100
½	0.622	131	90	72	62	55	50	46	42	40	38
¾	0.824	273	188	151	129	114	104	95	89	83	79
1	1.049	514	353	284	243	215	195	179	167	157	148
1¼	1.380	1060	726	583	499	442	400	368	343	322	304
1½	1.610	1580	1090	873	747	662	600	552	514	482	455
2	2.067	3050	2090	1680	1440	1280	1160	1060	989	928	877
2½	2.469	4860	3340	2680	2290	2030	1840	1690	1580	1480	1400
3	3.068	8580	5900	4740	4050	3590	3260	3000	2790	2610	2470

Inlet Pressure 14.0 in wc (3.4 kPa) or less; 0.5 in wc (0.12 kPa) Pressure Drop											
Nominal Pipe Size, In.	Inside Diameter, In.	Length of Pipe, Ft.									
		10	20	30	40	50	60	70	80	90	100
½	0.622	172	118	95	81	72	65	60	56	52	50
¾	0.824	360	247	199	170	151	137	126	117	110	104
1	1.049	678	466	374	320	284	257	237	220	207	195
1¼	1.380	1390	957	768	657	583	528	486	452	424	400
1½	1.610	2090	1430	1150	985	873	791	728	677	635	600
2	2.067	4020	2760	2220	1900	1680	1520	1400	1300	1220	1160
2½	2.469	6400	4400	3530	3020	2680	2430	2230	2080	1950	1840
3	3.068	11300	7780	6250	5350	4740	4290	3950	3674	3450	3260

* 1 CFH of Natural Gas is approximately equal to 1 MBH; contact your gas suppliers for the actual heating value of your

Table 19: Equivalent Lengths of Standard Pipe Fittings & Valves (ft)

Nominal Pipe Size, Inc.	Inside	Valves (Screwed) - Fully Open				Screwed Fittings				
		Gate	Globe	Angle	Swing Check	45° Elbow	90° Elbow	180 Close Return Bend	90 Tee Flow Through Run	90 Tee, Flow Through Branch
½	0.622	0.4	17.3	8.7	4.3	0.7	1.6	3.5	1.6	3.1
¾	0.824	0.5	22.9	11.4	5.7	1.0	2.1	4.6	2.1	4.1
1	1.049	0.6	29.1	14.6	7.3	1.2	2.6	5.8	2.6	5.2
1¼	1.38	0.8	38.3	19.1	9.6	1.6	3.5	7.7	3.5	6.9
1½	1.61	0.9	44.7	22.4	11.2	1.9	4.0	9.0	4.0	8.0
2	2.067	1.2	57.4	28.7	14.4	2.4	5.2	11.5	5.2	10.3
2½	2.469	1.4	68.5	34.3	17.1	2.9	6.2	13.7	6.2	12.3
3	3.068	1.8	85.2	42.6	21.3	3.6	7.7	17.1	7.7	15.3

X. Gas Piping (continued)

Table 20: Specific Gravity Correction Factors

Specific Gravity	Correction Factor	Specific Gravity	Correction Factor
0.60	1.00	0.90	0.82
0.65	0.96	1.0	0.78
0.70	0.93	1.10	0.74
0.75	0.90	1.20	0.71
0.80	0.87	1.30	0.68
0.85	0.81	1.40	0.66

16. The gas pressure switches will trip if the incoming gas pressure under or overshoot the switches' set point (see Table 21). A tripped switch is indicated by a neon light. Manual reset is required to reset the switch and resume boiler operation.

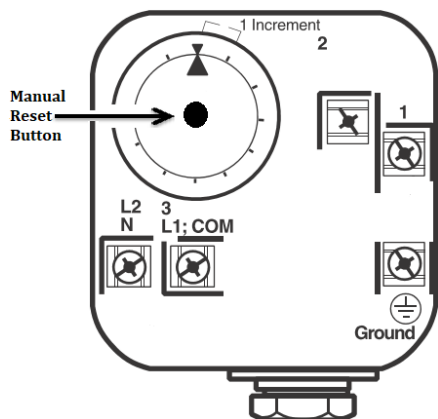

Figure 20: High/Low Gas Pressure Switch

Table 21: Inlet Gas Pressure

Boiler Model	Min. Gas Pres. (In. W.C.)	Max. Gas Pres. (In. W.C.)	High Gas Pressure Switch ¹ (In. W.C.)	Low Gas Pressure Switch ¹ (In. W.C.)	Inlet Size (In.)
AMP 1000	4	14	1	3	1
AMP 1250					1
AMP 1500					1.25
AMP 2000					1.25

¹ Factory default high and low gas pressure switch set point.

WARNING

Failure to properly pipe gas supply to boiler may result in improper operation and damage to the boiler or structure. Always assure gas piping is absolutely leak free and of the proper size and type for the connected load.

An additional gas pressure regulator may be needed. Consult gas supplier.

Failure to use proper thread compounds on all gas connectors may result in leaks of flammable gas.

Gas supply to boiler and system must absolutely shut off prior to installing or servicing boiler gas piping.

Do not use matches, candle, open flame or other ignition source to check for leaks.

Use two wrenches when tightening gas piping at boiler, use one wrench to prevent boiler gas train line from turning.

Failure to support the boiler connection pipe could damage safety components.

Ensure that the high gas pressure regulator is at least 10 feet (3 m) upstream of the appliance.

XI. Electrical

A. **General.** Install wiring and electrically ground boiler in accordance with authority having jurisdiction or, in the absence of such requirements, follow the *National Electrical Code*, NFPA 70, and/or *Canadian Electrical Code* Part 1, CSA C22.1 Electrical Code.

A separate electrical circuit must be run from the main electrical service with an over-current device/disconnect in the circuit. A service switch is recommended and may be required by some local jurisdictions. Install the service switch in the line voltage “Hot” leg of the power supply. Locate the service switch such that the boiler can be shut-off without exposing personnel to danger in the event of an emergency.

B. Power Requirements

Nominal boiler current draw is provided in Table 22. These values are for planning purposes only and represent only the boiler’s power consumption. To obtain total system power consumption add any selected circulator and component current draws.

Table 22: Boiler Current Draw

Boiler Model	Line Voltage	
	120/1/60	208-240/1/60
AMP 1000	<9	<4.5
AMP 1250	<9	<4.5
AMP 1500	<11	<5.5
AMP 2000	<11	<5.5

C. **Boiler wiring.** Refer to Figures 22-24.

1. Connect to field wiring inside the control box, as shown in Figure 23. Inside the control box are five printed circuit boards (PCB’s).

Table 23: PCB Connections

Printed Circuit Boards	Functions/Connection
PCB-01	Line Voltage
PCB-02	Field Device
PCB-04	Sensors
PCB-05	EMS
PCB-06	Communications



DANGER

Electrical Shock Hazard: Positively assure all electrical connections are unpowered before attempting installation or service of electrical components or connections of the boiler or building. Lockout all electrical boxes with padlock once power is turned off.



WARNING

Electrical Shock Hazard: Failure to properly wire electrical connections to the boiler may result in serious physical harm.

Electrical power may be from more than one source. Make sure all power is off before attempting any electrical work.

Each boiler must be protected with a properly sized over-current device.

Never jump out or make inoperative any safety or operating controls.

The wiring diagrams contained in this manual are for reference purposes only. Each boiler is shipped with a wiring diagram attached to the front door. Refer to this diagram and the wiring diagram of any controls used with the boiler. Read, understand and follow all wiring instructions supplied with the control.



NOTICE

All wires, wire nuts, controls etc. are installer supplied unless otherwise noted.

When making low voltage connections, make sure that no external power source is present in the thermostat or limit circuits. If such a power source is present, it could destroy the boiler’s microprocessor control. One example of an external power source that could be inadvertently be connected to the low voltage connections is a transformer with old thermostat wiring.

Label all wires prior to servicing controls. Wiring errors can cause improper and dangerous operation.

XI. Electrical (continued)

2. 24VAC low voltage connections are located on the left side of PCB-02. Three fuses and one spare are provided.
3. 24VDC low voltage connections are located on the right side of PCB-01 (see Figure 23). One low voltage fuse and one spare is provided.

D. Line voltage connections

1. Connect 120 VAC power wiring to the line voltage terminal strip in the control box.
2. Provide and install a fused disconnect or service switch (12 AMP recommended) as required by the code.
2. To activate system or DWH pump wire as shown in Figure 23.

E. Low voltage connections

1. Route all low voltage wires through the junction box's knockouts in the rear of the boiler.
4. If outdoor temperature sensor is used, connect sensor to PCB-04, terminals 51 and 52. The boiler will adjust the target supply water temperature set point downwards as the outdoor air temperature increases.
 - a. The sensor should be located on the outside of the structure in an area where it will sense the average air temperature around the building. Avoid placing this sensor in areas where it may be covered with ice or snow. Locations where the sensor will pick up direct radiation from the sun should also be avoided.
 - b. Avoid placing the sensor near potential sources of electrical noise such as transformers, power lines, and fluorescent lighting. Wire the sensor to the boiler using 22 gauge or larger wire. As with the sensor, the sensor wiring should be routed away from sources of electrical noise. Where it is impossible to avoid such noise sources, wire the sensor using a 2 conductor, *UL Type CM, AWM Style 2092, 300 Volt 60 C* shielded



Appliance must be electrically grounded as required by National Electrical Code ANSI/NFPA 70-latest edition.

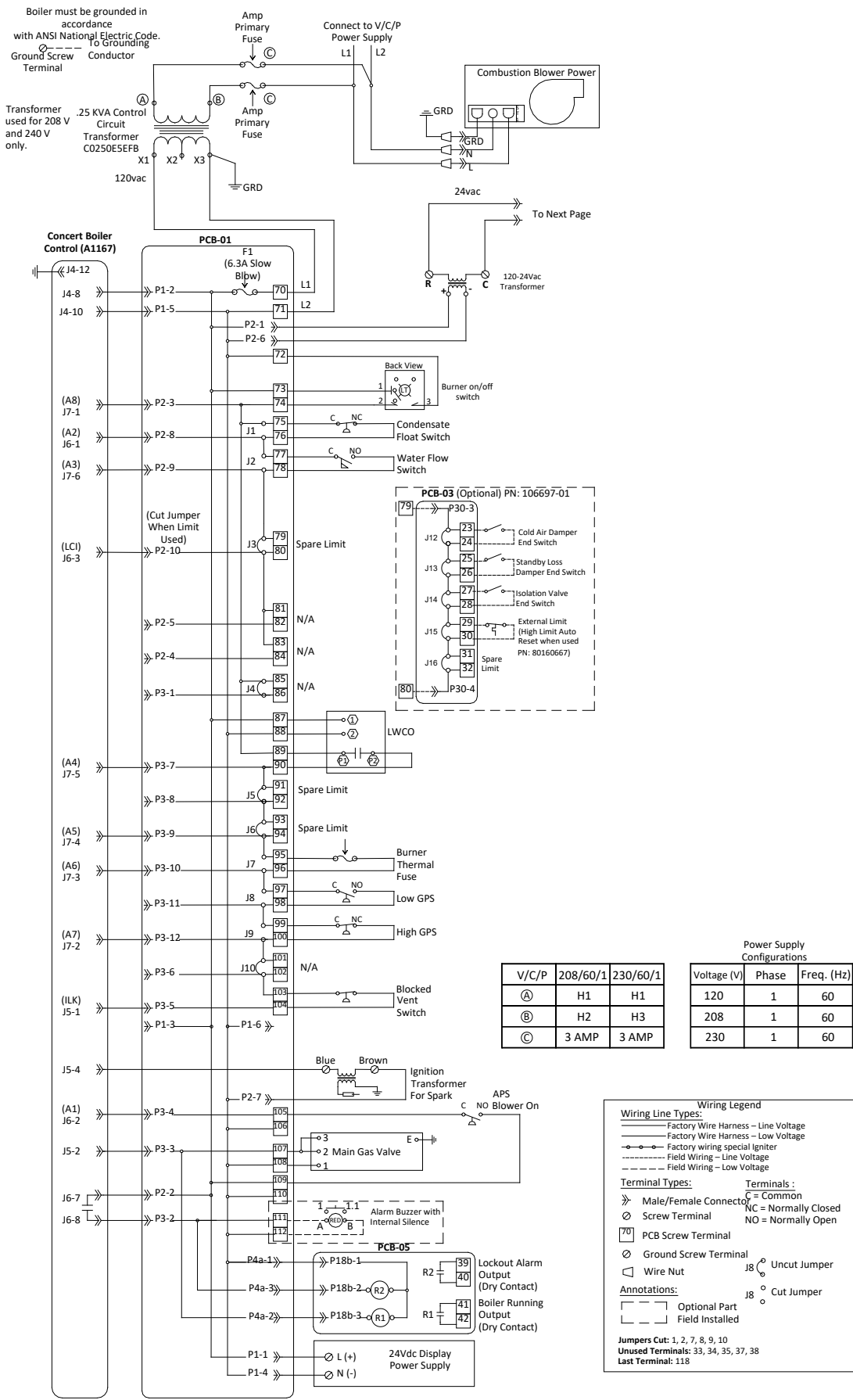

IMPORTANT: The wiring shown for devices supplied and installed by others is suggested only. Certification of, and responsibility for the correctness of the wiring is the responsibility of the supplier of these devices. Thermal Solutions accepts no responsibility for the correctness or safety or execution of this wiring or of the operation of such devices.

Figure 21: Ladder Diagram

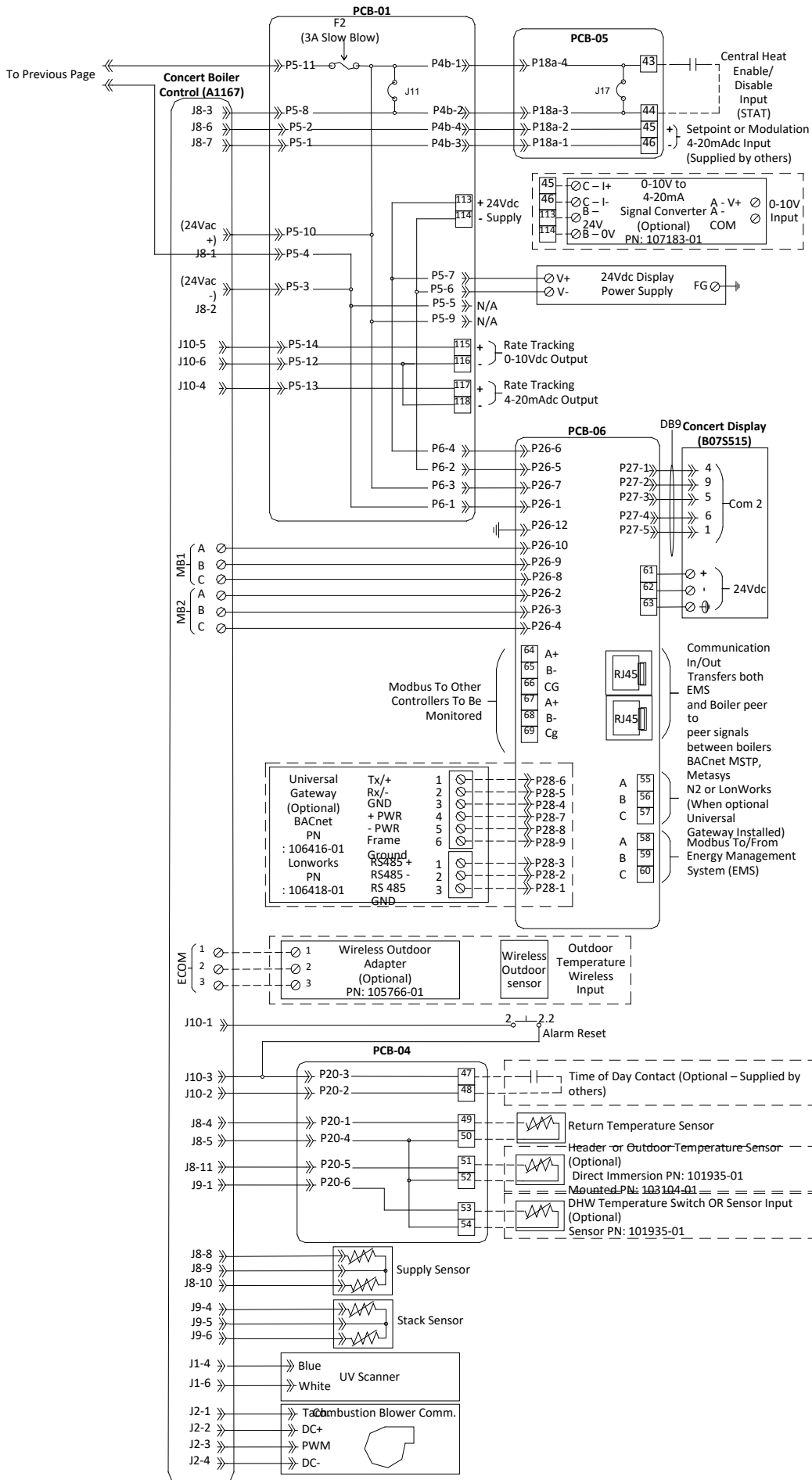

Figure 22: Ladder Diagram continued...

Concert Boiler Control (A1167)

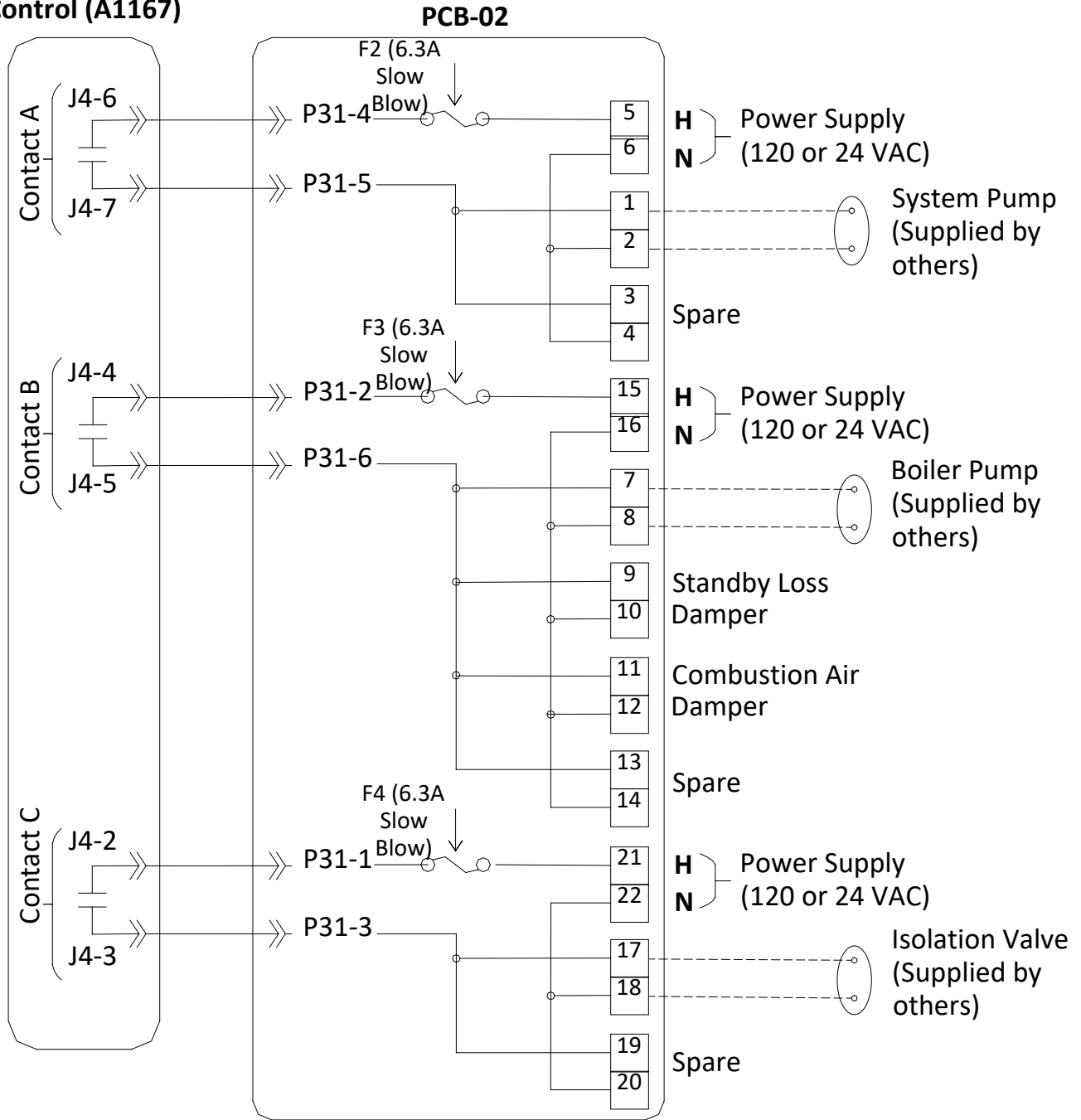

Figure 23: Ladder Diagram continued...

XII. System Start-up

A. Check Heating System.

1. Verify that the venting, water piping, gas piping and electrical system are installed properly. Refer to installation instructions contained in this manual.
2. Confirm all electrical, water and gas supplies are turned off at the source and that venting is clear of obstructions.
3. Flush the system to remove sediment, flux and traces of boiler additives. This must be done with the boiler isolated from the system. Fill heating system with water meeting the following requirements:
 - a. Water pH level between 7.5-9.5, if system contains aluminum components, pH must be less than 8.5
 - b. Chlorides < 50 ppm
 - c. Total dissolved solids less than 350 ppm
 - d. Water hardness 3-9 gpg
4. Pressurize the hydronic system. Fill entire heating system with water and vent air from the system.
 - a. Maintain 15 psi boiler loop pressure.
5. Power the boiler. Turn on the electrical supply to the boiler and circulator system at fuse disconnect switch.
6. Power the circulator(s). Turn system circulators on and purge air from the system.
7. Pressurize the fuel line.
 - a. Open the manual gas shut-off valves located upstream of the field supplied gas regulator.
 - b. Check gas piping for leaks and purge gas line of air.
 - c. Ensure the incoming gas pressure and the setting for the high and low gas pressure switches are within the limits given in Table 21.
 - d. Reset high and low gas pressure switches. (See Figure 20).

B. Start Boiler

Start the boiler using "Operating Instructions" in Figure 24.

1. Allow the boiler to complete its standard startup sequence: pre-purge, pre-ignition, and drive light-off.
2. Refer to the Concert Boiler Control manual to select the desired control mode.



Do not use matches, candles, open flames or other ignition source to check for leaks.

Make sure that the area around the boiler is clear and free from combustible materials, gasoline and other flammable vapors and liquids.



Start-up of this boiler should be undertaken only by trained and skilled personnel from a qualified service agency. Follow these instructions exactly. Improper installation adjustment, service or maintenance can cause property damage, personal injury or loss of life.

The maximum operating pressure of this boiler is 30 psig (210 kPa), 50 psig (340 kPa), 60 psig (410 kPa), 80 psig (550 kPa) or 100 psig (689 kPa) depending on the model and safety relief valve option selected. Never exceed the maximum allowable working pressure on the heat exchanger ASME plate.

The outlet pressure for the gas valve has been factory set and requires no field adjustment. Attempting to adjust the outlet pressure may result in damage to the gas valve and cause property damage, personal injury or loss of life.

Each AMP Series boiler is tested at the factory and adjustments to the air fuel mixture are normally not necessary. Improper gas valve or mixture adjustments could result in property damage, personal injury or loss of life.

Any gas valve adjustments (throttle and/or offset) specified herein and subsequent combustion data (%O₂, %CO₂, CO air free ppm) collection must be performed using a calibrated combustion analyzer.



To reduce lime scale buildup and prolong the life of the appliance, closely monitor pH, chloride, total dissolved solids, and water hardness levels.

XII. System Start-up(continued)

FOR YOUR SAFETY READ BEFORE OPERATING/POUR VOTRE SECURITE LISEZ AVANT DE METTRE EN MARCHÉ	
<p>WARNING: If you do not follow these Instructions exactly, a fire or explosion may result causing property damage, personal injury or loss of life.</p> <p>AVERTISSEMENT: Quiconque ne respecte pas à la lettre les instructions dans la présente notice risque de déclencher un incendie ou une explosion entraînant des dommages, des blessures ou la mort.</p>	
<p>A. This appliance does not have a pilot. It is equipped with an ignition device which automatically lights the burner. Do <u>not</u> try to light the burner by hand.</p> <p>B. BEFORE OPERATING smell all around the appliance area for gas. Be sure to smell next to the floor because some gas is heavier than air and will settle on the floor.</p> <p>WHAT TO DO IF YOU SMELL GAS:</p> <ul style="list-style-type: none"> • Do not try to light any appliance. • Do not touch any electric switch; do not use any phone in your building. • Immediately call your gas supplier from a neighbor's phone. Follow the gas supplier's instructions. • If you cannot reach your gas supplier, call the fire department. <p>C. Use only your hand to push in or turn the gas control knob. Never use tools. If the knob will not turn by hand, don't try to repair it, call a qualified service technician. Force or attempted repair may result in a fire or explosion.</p> <p>D. Do not use this appliance if any part has been under water. Immediately call a qualified service technician to inspect the appliance and to replace any part of the control system and any gas control which has been under water.</p>	<p>A. Cet appareil ne comporte pas de veilleuse. Il est muni d'un dispositif d'allumage qui allume automatiquement le brûleur. Ne tentez pas d'allumer le brûleur manuellement.</p> <p>B. AVANT DE FAIRE FONCTIONNER, reniflez tout autour de l'appareil pour déceler une odeur de gaz. Reniflez près du plancher, car certains gaz sont plus lourds que l'air et peuvent s'accumuler au niveau du sol.</p> <p>QUE FAIRE SI VOUS SENTEZ UNE ODEUR DE GAZ:</p> <ul style="list-style-type: none"> - Ne pas tenter d'allumer d'appareil. - Ne touchez à aucun interrupteur ; ne pas vous servir des téléphones se trouvant dans le bâtiment. - Appelez immédiatement votre fournisseur de gaz depuis votre voisin. Suivez les instructions du fournisseur. - Si vous ne pouvez rejoindre le fournisseur, appelez le service des incendies. <p>C. Ne poussez ou tournez la manette d'admission du gaz qu'à la main ; ne jamais utiliser d'outil. Si la manette reste coincée, ne pas tenter de la réparer ; appelez un technicien qualifié. Le fait de forcer la manette ou de la réparer peut déclencher une explosion ou un incendie.</p> <p>D. N'utilisez pas cet appareil s'il a été plongé dans l'eau, même partiellement. Faites inspecter l'appareil par un technicien qualifié et remplacez toute partie du système de contrôle et toute commande qui ont été plongés dans l'eau.</p>
OPERATING INSTRUCTIONS/INSTRUCTIONS DE FONCTIONNEMENT	
<ol style="list-style-type: none"> 1. STOP! Read safety information above (to the left) on this label. 2. Set the thermostat to lowest setting. 3. Turn off all electric power to the appliance. 4. This appliance is equipped with an ignition device which automatically lights the burner. Do <u>not</u> try to light the burner by hand. 5. Turn the external boiler manual gas valve handle clockwise ↻ to close the gas supply. 6. Wait five (5) minutes to clear out any gas. Then smell for gas, including near the floor. If you smell gas, STOP! Follow "B" in the safety information above (to the left) on this label. If you don't smell gas, go to the next step. 7. Turn the external boiler manual gas valve handle counterclockwise ↺ to open the gas supply. 8. Turn on all electric power to the appliance. 9. Set the thermostat to the desired setting. 10. If the appliance will not operate, follow the instructions "To Turn Off Gas To Appliance" and call your service technician or gas supplier. 	<ol style="list-style-type: none"> 1. ARRÊTEZ ! Lisez les instructions de sécurité sur la portion supérieure (à gauche) cette étiquette. 2. Réglez le thermostat à la température la plus basse. 3. Coupez l'alimentation électrique de l'appareil. 4. Cet appareil est équipé de l' dispositif d'allumage qui allume automatiquement le brûleur. Ne pas essayer d'allumer le brûleur par la main. 5. Tourner la chaudière externe manuelle poignée ↻ en clapet à gaz dans le sens des aiguilles d'une montre pour fermer l'offre de gaz. 6. Attendre cinq (5) minutes pour laisser échapper tout le gaz. Reniflez tout autour de l'appareil, y compris près du plancher, pour déceler une odeur de gaz, ARRÊTEZ ! Passez à l'étape B des instructions de sécurité sur la portion supérieure (à gauche) cette étiquette. S'il n'y a pas d'odeur de gaz, passez à l'étape suivante. 7. Tourner la chaudière externe manuelle poignée ↺ en clapet à gaz ouvrir dans le sens des aiguilles d'une montre le gaz approvisionnement. 8. Allumer toute l'énergie électrique au appareil. 9. Réglez le thermostat à la température désirée. 10. Si l'appareil ne se met pas en marche, suivez les instructions intitulées « Comment couper l'admission de gaz de l'appareil » et appelez un technicien qualifié ou le fournisseur de gaz.
<p>OPEN/OUVERT CLOSED/FERMÉ</p>  <p>EXTERNAL BOILER MANUAL GAS VALVE LA CHAUDIÈRE EXTERNE MANUELLE DE CLAPET À GAZ</p>	
TO TURN OFF GAS TO APPLIANCE/COMMENT COUPER L'ADMISSION DE GAZ DE L'APPAREIL	
<ol style="list-style-type: none"> 1. Set the thermostat to lowest setting. 2. Turn off all electric power to the appliance if service is to be performed. 3. Turn the external boiler manual gas valve handle clockwise ↻ to close gas supply. 	<ol style="list-style-type: none"> 1. Réglez le thermostat à la température la plus basse. 2. Coupez l'alimentation électrique de l'appareil s'il faut procéder à l'entretien. 3. Tourner la chaudière externe manuelle poignée ↻ en clapet à gaz dans le sens des aiguilles d'une montre pour fermer l'offre de gaz.
<p>101607-01R2</p>	

Figure 24: Operating Instructions

XII. System Start-up(continued)

3. It may take a couple of ignition attempts before a flame is established. After the first ignition failure, the boiler goes into a hard lockout and a manual reset of the Convert Boiler Control is required to restart the boiler. If ignition is not achieved in three consecutive attempts, contact factory or a qualified heating service technician.
4. Begin commissioning the boiler. Visually inspect flame via sight class window. On high fire the flame should be stable and mostly blue. Yellow tips should not be present; but, intermittent flecks of yellow and orange in the flame are normal.

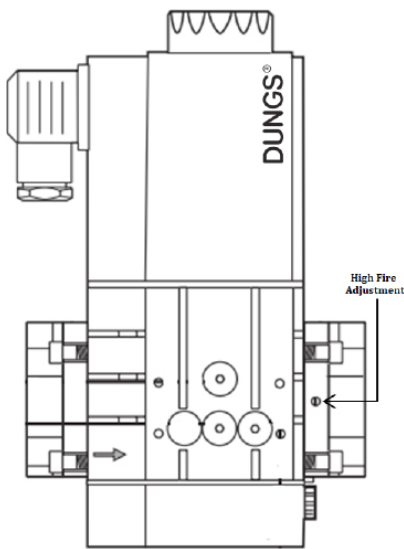

Figure 25: Air-to-Fuel Adjustment

5. Verify O_2 (or CO_2) and CO concentration are within limits specified in Table 21. Note: the values in Table 21 are for sea level only. For high altitude installation, above 2000 ft. consult factory.
 - a. Lock boiler in high fire and allow fan speed and combustion analyzer reading to stabilize before taking combustion readings. To lock boiler in high fire, select MAIN MENU >> OPERATION. Select lock symbol, type password and select ENTER. From the Operation screen, select Automatic / Manual Firing Rate Control >> Manual Modulation. Go back to Operation screen. Then select High Low >> High.
 - b. Once boiler has reached high fire rate, adjust the O_2 level at high fire with all the jackets, including the front cabinet door closed.

Table 24: Combustion O_2 Levels

Boiler Model	CO_2 %	O_2 %	CO air free (PPM)
AMP 1000	8.5-9.0	5.0-6.0	Less than 200 PPM
AMP 1250	8.5-9.0	5.0-6.0	
AMP 1500	8.0-9.0	5.0-6.0	
AMP 2000	8.5-9.0	5.0-6.0	

- c. For boilers specified to be less than 20 ppm NO_x adjust O_2 level to 6.0 %.
 - d. If high fire O_2 is too high (CO_2 is too low), decrease O_2 (increase CO_2) by turning the adjustment screw towards the "Plus (+)" sign in 1/4 turn increments and checking the O_2 (or CO_2) after each adjustment. Refer to Figure 25 for location of throttle screw. Verify CO air free is less than 200 ppm.
 - e. Lock boiler in low fire and allow fan speed and combustion analyzer reading to stabilize before taking combustion readings. To lock boiler in low fire, select High Low >> Low.
 - f. If low fire O_2 is too low (CO_2 is too high), increase O_2 (decrease CO_2) by turning turn adjustment screw towards "Minus (-)" sign in less than 1/8 turn increments and checking the O_2 (or CO_2) after each adjustment. Verify CO concentration is less than 200 ppm.
 - g. If low fire O_2 is too high (CO_2 is too low), decrease O_2 (increase CO_2) by turning the adjustment screw towards the "Plus (+)" sign in 1/4 turn increments and check O_2 (or CO_2) after each adjustment. Verify CO air free is less than 200 ppm.
 - h. Verify O_2 repeatability by modulating the boiler to high and low fire three times.
 - i. Once the boiler is operating within the specified high and low fire ranges, record emissions, flue draft, and other important data.
 - j. Compare emission data to the factory emissions report is posted on the back of the front jacket panel
6. Return boiler to Automatic Mode. From Operation screen, select Automatic / Manual Firing Rate Control >> Automatic Modulation. Select HOME to return boiler to Home Screen.

XII. System Start-up(continued)

B. Test Safety Limits Controls

1. Test the ignition system safety shut-off by disconnecting the flame sensor connector (black plug with orange wire) from the flame ionization electrode. The boiler must shut down and must not start with the flame sensor disconnected.
2. Test the flow switch by disabling the primary loop circulator. The boiler must not start if flow is not present.
3. Test any other external limits or other controls in accordance with the manufacturer's instructions.

C. Check Thermostat Operation

Verify that the boiler starts and stops in response to calls for heat from the heating thermostat and indirect water heater thermostat. Make sure that the appropriate circulators also start and stop in response to the thermostats.

D. Adjust Supply Water Temperature

As shipped, the Central heat (CH) set point supply temperature set point is 180°F (82.2°C) and, domestic hot water (DHW) supply temperature is set point is 170°F (76.7°C). If necessary, adjust these to the appropriate settings for the type of system to which this boiler is connected. For information on how to adjust central heat, refer to "Setup and Tuning" section of the Concert™ Boiler Manual.

E. Adjust Thermostats

Adjust the CH and DHW thermostats to their final set points.

F. Testing of Controls and Safety Devices

Prior to placing the boiler in operation, the installing contractor or other responsible personnel must perform safety and control device limit tests to ensure proper operation of the appliance. Refer to Table 25 for recommended method(s) of carrying out these safety limit devices tests.



WARNING

Make sure that all adjustments at high fire are made with the throttle, not offset screw (see Figure 26).

The offset screw has been factory set using precision instruments and must never be adjusted in the field unnecessarily.

Attempting to adjust the offset screw could result in damage to the gas valve and may cause property damage, personal injury or loss of life.

Each AMP Series boiler is tested at the factory and adjustments to the air fuel mixture are normally not necessary. Improper gas valve or mixture adjustments could result in property damage, personal injury or loss of life.

XII. System Start-up(continued)

Table 25: Safety Device Test

Safety Device Test			
Component	Test Method(s)	After Lockout Annunciation	Actual Alarm Message
High Gas Pressure Switch	Close factory supplied manual gas valve outside of boiler jacket. Cycle Boiler.	Manually reset the Concert Boiler Control and switch. Adjust the switch to its normal setting.	Hard Lockout. Gas Pressure Switch
Low Gas Pressure Switch	Increase the setting of the switch until the switch trips.	Manually reset the Concert Boiler Control and switch. Adjust the switch to its normal setting.	Hard Lockout. Gas Pressure Switch
Burner Thermal Fuse	Disconnect one wire of the burner thermal fuse. Cycle the boiler.	Re-connect wiring to the burner thermal fuse. Reset burner thermal fuse lockout.	Hard Lockout. Burner Thermal Fuse
Blocked Condensate Switch	Disconnect one wire of the blocked condensate switch. Cycle the boiler.	Re-connect wire to the blocked condensate switch. Reset the blocked condensate switch lockout.	Hard Lockout. Blocked Condensate switch
Low Water Cutoff	While the boiler running push and hold the LWCO test button until the boiler control shuts down the main burner.	Manually reset the Concert Boiler Control and reset the LWCO	Hard Lockout. Low Water Level.
Water Flow Switch	Reduce the water flow rate with a manual shutoff valve until the boiler shuts down.	Adjust manual valve to normal position.	Low Water Flow

**IMPORTANT PRODUCT SAFETY INFORMATION
REFRACTORY CERAMIC FIBER PRODUCT**

WARNING:

The Repair Parts list designates parts that contain refractory ceramic fibers (RCF). RCF has been classified as a possible human carcinogen. When exposed to temperature above 1805 °F, such as during direct flame contact, RCF changes into crystalline silica, a known carcinogen. When disturbed as a result of servicing or repair, these substances become airborne and, if inhaled, may be hazardous to your health.

AVOID Breathing Fiber Particulates and Dust

Precautionary Measure:

Do not remove or replace RCF parts or attempt any service or repair work involving RCF without wearing the following protective gears:

1. A National Institute for Occupational Safety and Health (NIOSH) approved respirator
 2. Long sleeved, loose fitting clothing
 3. Gloves
 4. Eye Protection
- Take steps to assure adequate ventilation
 - Wash all exposed body area gently with soap and water after contact.
 - Wash work clothes separately from other laundry and rinse washing machine after use to avoid contaminating other clothes.
 - Discard used RCF components by sealing in an airtight plastic bag. RCF and crystalline silica are not classified as hazardous wastes in the United State and Canada.

First Aid Procedures:

- If contact with eyes: Flush with water for at least 15 minutes. Seek immediate medical attention if irritation persists.
- If contact with skin: Wash affected area gently with soap and water. Seek immediate medical attention if irritation persists.
- If breathing difficulty develops: Leave the area and move to a location with clean fresh air. Seek immediate medical attention if breathing difficulties persist.
- Ingestion: DO not induce Vomiting. Drink plenty of water. Seek immediate medical attention.

XIII. Service and Maintenance

A. Inspect Boiler Area

1. Keep the area around the boiler free from combustible materials-- gasoline and other flammable vapors and liquids (see Table 4).
2. Keep the area around the combustion air inlet terminal free from contaminants.
3. Keep the boiler room ventilation orifices open and unobstructed.

B. Boiler Interior

1. Remove front jacket panel and check minimum and blocked vent switches for cracks and check pressure sensing line connections.
2. Vacuum any sediment and dust from boiler interior and components.

C. Monthly Inspection

1. Inspect the vent piping and outside air intake piping to verify they are open, unobstructed and free of leakage or deterioration. Check screens in vent and air intake terminals to verify they are clean and free of debris.
2. Inspect the condensate drain system to verify it is leak proof, open and unobstructed. Call the service technician if the condensate drain system requires maintenance.
3. Inspect water and gas lines to verify they are free of leaks.

D. Annual Inspections and Service

In addition to the inspection listed above the following should be performed by a service technician once every year.

1. Water flow switch
 - i. Test the flow switch by disabling the boiler primary loop circulator. The boiler must not start when there is no water flow.
 - ii. Remove flow switch and visually inspect paddle length. The markings, AMP 20 and AMP 10-15, shown in Figure 26 should be visible for a specific size boiler.

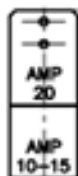

Figure 26: Paddle Markings

Table 26: Water Flow Requirements

Boiler Model	Max. Flow (GPM)	Min. Flow (GPM)	Water ¹ Vol. (Gal.)
AMP 1000	450	35	10.96
AMP 1250	450	44	10.96
AMP 1500	450	53	12.97
AMP 2000	550	71	16.72

¹Heat exchanger water volume.



Read and understand the entire manual before attempting installation, start-up operation, or service. Installation and service must be performed only by an experienced, skilled, and knowledgeable installer or service agency.

The boiler requires regular maintenance and service to operate safely. Follow the instructions contained in this manual. Improper installation, adjustment, alteration, service or maintenance can cause property damage, personal injury or loss of life.

A clean and unobstructed venting system is necessary to allow noxious fumes that could cause injury or loss of life to vent safely, and will contribute toward maintaining the boiler's efficiency.

Installation is not complete unless a safety relief valve is installed in the tapping located on the water manifold or supply piping. Refer to the Hydronic Piping section of the manual.

If damage due to frozen pipes is a possibility, the heating system should be not left unattended in cold weather; or appropriate safeguards and alarms should be installed on the heating system to prevent damage if the boiler is inoperative.

Do not unscrew any pipe fittings nor attempt to disconnect any components of this boiler without positively assuring the water is cool and has no pressure. Always wear protective clothing and equipment when installing, starting up or servicing this boiler to prevent scald injuries. Do not rely on the pressure and temperature gauge to determine the temperature and pressure of the boiler.

XIII. Service and Maintenance (continued)

2. Ignitor electrode and UV Scanner

- i. Disconnect power to the unit and remove ignition electrode from the burner door.
- ii. Visually inspect ignitor assembly (ceramic insulators, bracket and graphite gasket) for damage. Replace ignitor assembly if the electrodes are deformed or ceramic insulators are cracked.

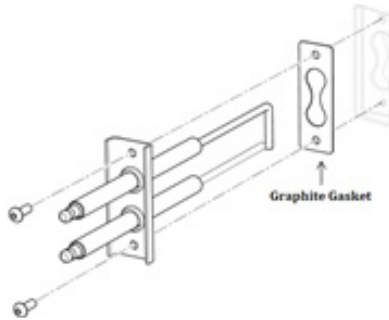

Figure 27: Ignitor Electrode Assembly

- iii. Remove any excess oxide deposits from the surface of the ignitor with steel wool or emery cloth. Do not use sandpaper.
- iv. Install ignitor electrode in the orientation shown in Figure 27; otherwise, the unit will not light.

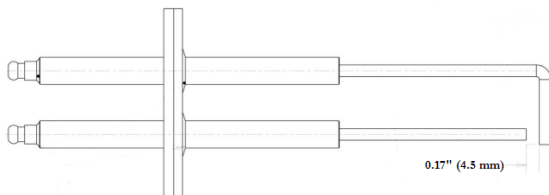

Figure 28: Ignitor Electrode Gap

- v. After reinstalling the ignitor, make sure there is a $\frac{3}{8}$ inch gap between the ignitor and the burner surface. Refer to Figure 28 "Ignitor Electrode Gap" for details.
 - vi. Inspect ultra-violet (uv) scanner lens and remove any debris with soft cloth and make sure that hole is clear from scanner to burner.
- #### 3. Ignitor electrode and UV Scanner
- i. To gain access to burner and combustion chamber, first remove front jacket panel and then disconnect gas inlet pipe from gas valve at the union connection.
 - ii. Remove the front left side jacket panel.
 - iii. Remove all eight bolts (M10 x 40) used to fasten burner door to heat exchanger.



The boiler uses flammable gas, high voltage electricity, moving parts and very hot water under high pressure. Assure that all gas and electric power supplies are off and that the water temperature is cool before attempting any disassembly or service.

Do not attempt any service work if gas is present in the air in the vicinity of the boiler. Never modify, remove or tamper with any control device.



The boiler contains components which become very hot when the boiler is operating. Do not touch any components unless they are cool.

Boiler materials of construction, products of combustion and the fuel contain alumina, silica, heavy metals, carbon monoxide, nitrogen oxides, aldehydes and/or other toxic or harmful substances which can cause death or serious injury and which are known to the state of California to cause cancer, birth defects and other reproductive harm. Always use proper safety clothing, respirators and equipment when servicing or working nearby the appliance.

Failure to follow all instructions in the proper order can cause personal injury or death. Read all instructions, including all those contained in component manufacturers manuals which are provided with the boiler before installing, starting up, operating, maintaining or servicing. All cover plates, enclosures and guards must be in place at all times.

If any controls are replaced, they must be replaced with identical models.

If any electrical wires are disconnected during service, clearly label the wires and assure that the wires are reconnected properly.

Never jump out or bypass any safety or operating control or component of this boiler.

Interior of the venting system must be inspected and clean before the start of the heating season and should be inspected periodically throughout the heating season for any obstructions.

XII. Service and Maintenance (continued)

- iv. The unit is equipped with a sliding mechanism shown in Figure 29. Position (1) shows the burner assembly sliding out of the combustion chamber; (2) rotate away from the combustion chamber and (3) sliding back to allow full access to the combustion chamber for inspection and service.

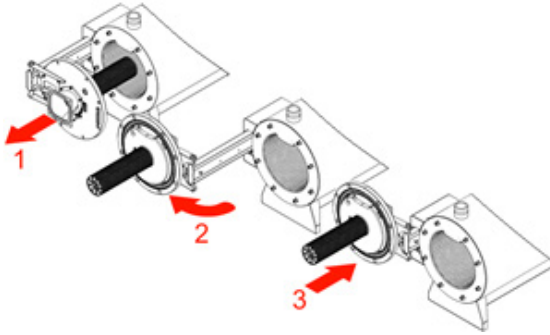

Figure 29: Burner Door

- v. Gently blow compressed air over the burner surface and door insulation to remove lint and debris. Replace burner if the surface shows any signs of damage due to improper handling or gas valve combustion settings.
- vi. Do not use acid or alkali products or metallic brush to clean the heat exchanger coils. Follow these guidelines to clean the heat exchanger:
- Spray the heat exchanger coils with white vinegar (acetic acid) and then flush it with clean water after 20 minutes.
 - Do not spray burner, combustion chamber divider and burner door insulations .
4. Flue outlet connection
- Visually inspect flue outlet gasket for damage or deterioration, replace if necessary.
 - Any accumulation of soot or debris should be thoroughly cleaned out.
5. Flue outlet connection
- Remove air intake pipe to gain access to the filter. Blow compressed air through the filter to remove dust and debris.
 - Replace filter if it appears damaged or deteriorated.
 - Reinstall air filter and intake pipe.
6. Insulations and gaskets
- Visually inspect the following gaskets: flue outlet, blower, burner, burner door.

WARNING

Failure to properly secure the burner/blower/gas valve assembly to the heat exchanger could lead to property damage, personal injury or loss of life.

Read, understand and follow all the instructions and warnings contained in ALL of the component instruction manuals.

Assure that all safety and operating controls and components are operating properly before placing the boiler back in service.

Annually inspect all vent gaskets and replace any exhibiting damage or deterioration.

Use only inhibited propylene glycol solutions specifically formulated for hydronic systems. Do not use ethylene glycol, which is toxic and can attack gaskets and seals used in hydronic systems. Use of ethylene glycol could result in property damage, personal injury or death.

NOTICE

This boiler has a limited warranty, a copy of which is included with this boiler. It is the Responsibility of the installing contractor to see that all controls are correctly installed and are operating properly when the installation is complete.

Warranty does not cover boiler damage or malfunction if the following steps are not performed at the intervals specified.

Water leaks can cause severe corrosion damage to the boiler or other system components. Immediately repair any leaks found.

XII. Service and Maintenance (continued)

E. Restarting after Prolong Shutdown

After prolonged shutdown, it is recommended that the "System Startup and Service and Maintenance" of this manual be performed.

XIV. Troubleshooting

Refer to the troubleshooting section in the Concert Boiler Control manual on how to navigate the Limit String Status screen which shows an active safety limit status and for an in-depth guide to all the possible lockouts as well as recommended corrective actions for restore boiler operation.

XV. Repair Parts

All AMP Repair Parts may be obtained through your local authorized Thermal Solutions representatives or outlets. Should you require assistance in locating a Thermal Solutions representative or outlet in your area, or have questions regarding the availability of Thermal Solutions Products or repair parts, please contact Thermal Solutions Customer Service at **(717) 239-7642** or Fax **(877) 501-5212**

APPENDIX A - TABLES

Table Number	Page Number	Description
Section III - Product Ratings, Specifications & Dimensional Data		
Table 1	7	Ratings
Table 2	7	Specifications
Table 3	8	Dimensional Data
Section VI - Pre-Installation and Boiler Mounting		
Table 4	16	Corrosive Combustion Air Contaminants
Table 5	17	Combustible and Recommended
Section VII - Venting		
Table 6	18	Vent/Air Intake Options
Table 7	19	Vent and Combustion Air Pipe Sizes and Equivalent Lengths
Table 8	19	Vent System and Combustion Air System Component Equivalent Length
Table 9	19	Vent and Combustion Air Equivalent Length Calculation Worksheet
Table 10	19	Recommended Polypropylene Vent Pipe Adapter and Suppliers
Section VIII - Condensate Disposal		
Table 11	33	Maximum Condensate Flow
Table 12	34	Condensate Neutralizer Kit
Section IX - Hydronic Piping		
Table 13	36	Temperature Rise
Table 14	36	Increase Flow For Glycol System
Table 15	40	Water Hardness Level
Table 16	40	Recommended Corrosion/Scale Inhibitors Removal Agent Suppliers
Table 17	40	Treatment Type
Section X - Gas Piping		
Table 18	44	Maximum Capacity of Schedule 40 Black Pipe in CFH (Natural Gas)
Table 19	44	Equivalent Lengths of Standard Pipe Fittings and Valves (ft)
Table 20	45	Specific Gravity Correction Factors
Table 21	45	Inlet Gas Pressure
Section XI - Electrical		
Table 22	46	Boiler Current Draw
Table 23	46	PCB Connections
Section XII - System Start-up		
Table 24	53	Combustion O ₂ Levels
Table 25	55	Safety Device Test
Table 26	57	Water Flow Requirements

APPENDIX B - FIGURES

Figure Number	Page Number	Description
Section III - Product Ratings, Specifications & Dimensional Data		
Figure 1	9	AMP- Models 1000-2000
Section VI - Component Identification		
Figure 2	12	Component Identification
Figure 3	13	Component Identification
Section V - Unpacking		
Figure 4	14	Lift Lugs
Section VI - Pre-Installation and Boiler Mounting		
Figure 5	17	Recommended Service and Combustible Material Clearance
Section VII - Venting		
Figure 6	20	Location of Vent Terminal Relative to Windows, Grades, Overhangs, Meters...
Figure 7	22	Sidewall Terminals
Figure 8	22	Vertical Terminations with Sloped Roof
Figure 9	24	Vertical Termination
Figure 10	27	Flexible Vent in Masonary Chimney with Separate Combustion Air Intake
Figure 11	31	Multiple Boiler Direct Termination
Section VIII - Condensate Disposal		
Figure 12	33	Condensate Trap Assembly
Section IX - Hydronic Piping		
Figure 13	35	Factory Supplied Manifold
Figure 14	36	Boiler Head Loss
Figure 15	41	Single Boiler-Recommended-Primary/Secondary Piping
Figure 16	41	Primary-Secondary Piping with Domestic Hot Water
Figure 17	42	Multiple Boiler-Primary/Secondary Piping
Figure 18	42	Multiple Boiler -Piping with Common Header
Section X - Gas Piping		
Figure 19	43	Recommended Gas Piping
Figure 20	45	High/Low Gas Pressure Switch
Section XI - Electrical		
Figure 21	48	Ladder Diagram
Figure 22	49	Ladder Diagram
Figure 23	50	Ladder Diagram
Section XII - System Start-up		
Figure 24	52	Operating Instructions
Figure 25	53	Air-to-Fuel Adjustment
Section XIII - Service and Maintenance		
Figure 26	57	Paddle Markings
Figure 27	58	Ignitor Electrode Assembly
Figure 28	58	Ignitor Electrode Spacing
Figure 29	59	Burner Door

APPENDIX C -DEFAULT LIGHT OFF AND MODULATION RPMs

Parameter	Boiler Model			
	AMP 1000	AMP 1250	AMP 1500	AMP 2000
Max Power MBTU	1000	1250	1500	2000
CH/DHW Max. Modulation Rate (RPM) ¹	6200	7600	4600	4800
Minimum Modulation Rate (RPM)	1725	2000	1250	1350
Light-off (RPM) ¹	2400	2400	1900	1900
Maximum Light-off (RPM)	2500	2500	2000	2000
Minimum Light-off (RPM)	2300	2300	1800	1800

¹ Factory Default RPM

NOTE: To maintain rate in maximum vent length application, contact factory for assistance.

APPENDIX D -INLET/OUTLET WATER AND FLUE OUTLET TEMPERATURE SENSOR RESISTANCE-VOLTAGE CHART

T(°C)	Rn(Ohm)
0	32624
5	25381
10	19897
15	15711
20	12493
<u>25</u>	<u>10000</u>
30	8056
35	6530
40	5324
45	4365
50	3599
55	2982
60	2483
65	2079
70	1748
75	1476
80	1252
85	1066
90	912
95	782
100	674

Resistance table

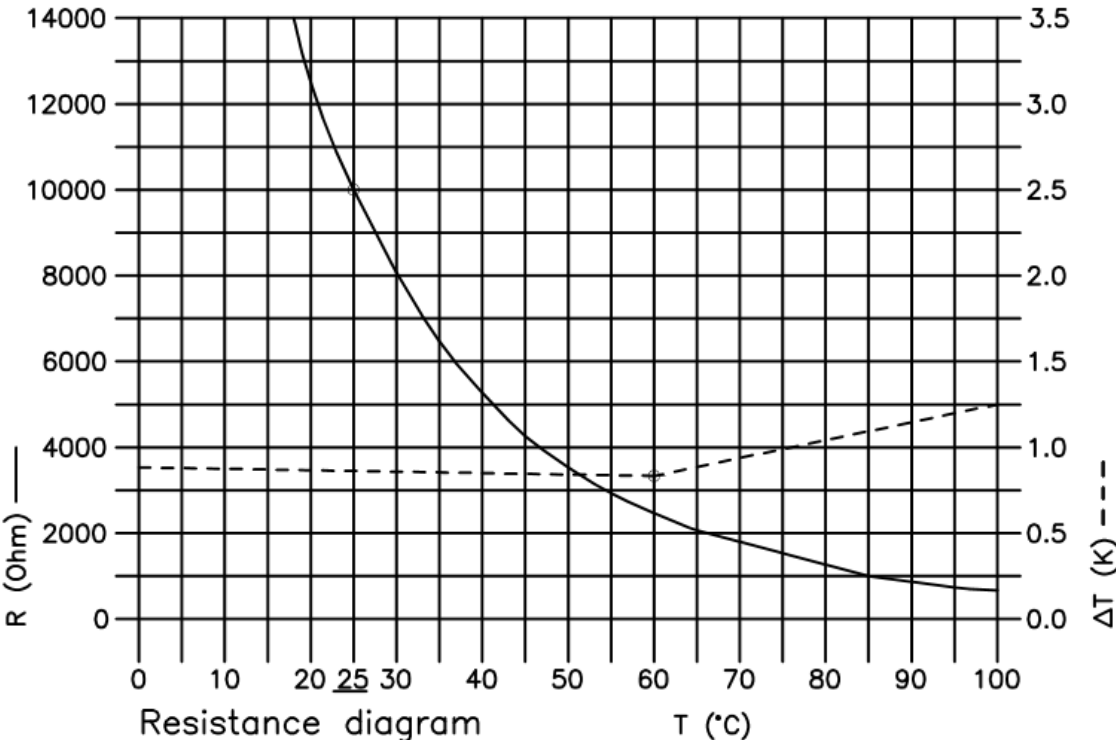

Resistance diagram

APPENDIX E: -VENT AND COMBUSTION AIR PRESSURE DROP DATA

The Combustion pressure drop through the vent and combustion air duct shall not exceed 200 equivalent feet. Use tables below to calculate the pressure drop in the vent/combustion air system.

AMP 1000 Pressure Drop in Equivalent Feet (Flue Vent)				
Flue Vent Diameter (in.)	Straight Length (eq. ft/ft)	90° Elbow (eq. ft/Bend)	45° Elbow (eq. ft/Bend)	Velocity (fpm)
6	1.40	14.28	6.90	1478
8	0.3	3.0	1.54	831
10	0.09	0.95	0.48	532
AMP 1250 Pressure Drop in Equivalent Feet (Flue Vent)				
6	2.17	2.17	11	1845
8	0.48	4.76	4.17	1038
10	0.15	1.48	0.74	664
AMP 1500 Pressure Drop in Equivalent Feet (Flue Vent)				
6	3.125	30	15	2211
8	0.69	6.90	3.45	1244
10	0.21	2.13	1.0	796
AMP 2000 Pressure Drop in Equivalent Feet (Flue Vent)				
6	5.55	54	27.59	2950
8	1.22	12.5	6.00	1660
10	0.377	3.77	1.87	1062

AMP 1000 Pressure Drop in Equivalent Feet (Combustion Air Duct)				
Flue Vent Diameter (in.)	Straight Length (eq. ft/ft)	90° Elbow (eq. ft/Bend)	45° Elbow (eq. ft/Bend)	Velocity (fpm)
6	0.73	7.4	3.70	1070
8	0.16	1.6	0.80	602
10	0.05	0.5	0.25	385
AMP 1250 Pressure Drop in Equivalent Feet (Combustion Air Duct)				
6	1.14	11	5.71	1340
8	0.25	2.25	1.25	754
10	0.078	0.78	0.40	482
AMP 1500 Pressure Drop in Equivalent Feet (Combustion Air Duct)				
6	1.67	16.67	8.33	1610
8	0.36	3.64	1.82	906
10	0.11	1.14	0.57	580
AMP 2000 Pressure Drop in Equivalent Feet (Combustion Air Duct)				
6	2.94	28.75	14.28	2150
8	0.64	6.45	3.2	1210
10	0.2	2	1	744

